



ER Floating Chuck

Parallel floating for perfect holes

Floating chucks

Floating chucks are practical problem solvers that have existed for over 100 years. Still these products are not very well known and continue to be of use on many modern machines. Below are the advantages of the floating chuck.

History of the floating chuck

Floating chucks are first mentioned in a patent of H. J. Watts of Turtle Creek, PA. The patent was filed as; FLOATING TOOL CHUCK, on November 30th, 1915 and granted September 25, 1917. It is not known how well the system worked or any units survived.

What is a floating chuck?

When using reamers on lathes it is often necessary to compensate for axis error between the chuck and the bore to be machined. This error can be corrected by using a self-centering floating chuck. The floating chuck perfectly adjusts the alignment between the reamer and the workpiece hole and ensures the same accuracy as the reamer itself.

What are the advantages of a floating chuck?

A unique self-centering mechanism eliminates "tapered & oversized" holes and improves the surface finish.

How does a floating chuck technically work?

A parallel floating mechanism compensates for misalignment between reamer and workpiece. A unique ball bearing and axle drive shaft structure allows both smooth vertical and horizontal operations under high torque in reaming. In certain machine tools such as semiautomatic lathes, swiss lathe machines or boring machines, it is difficult to use reamers properly for the execution of perfectly gauged bores having an excellent surface condition. This difficulty is due to a misalignment which, in the case of semiautomatic lathes, is due to an expansion of the headstock during operation and, in the case of swiss lathe machines, is generally due to wear.

What does this mean for you?

With faster reaming operations, the productivity will increase due to quality issues by the increased surface quality and bore precision.

Tool life will also significantly increase because of symmetric reamer wear and tolerances are met for a longer production time.

Problems where the floating chuck always is beneficial:

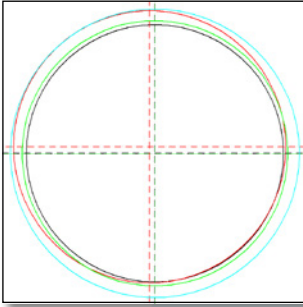

Misalignment | Problems

- // Original bore (black)
- // Reamer with radial error (red)
- // Reaming with radial error (blue)
- // Reaming with floating holder (green)



Bore becomes too large | Problems

- // Lack of cooling lubricant, formation of built-up edges
- // Irregularity of the cutting angle
- // Bore too small, friction tolerances too high
- // Axial offset between tool and pilot hole



Conical bore (entry too large) | Problems

- // Tool unstable in the axis
- // Pre-drilling not centered
- // Axial offset between tool and pilot hole
- // Chip formation in the upper bore area



Conical bore (end too large) | Problems

- // Axial offset between pre-bore and reamer axis
- // Chips in the lower hole area reamer pressing on hole bottom

Problems where the floating chuck always is beneficial:



Poor surface quality | Problems

- // Reamer or pilot hole damaged
- // Cooling lubricant missing
- // Poor chip removal
- // Misalignment between pre-bore and reamer axis

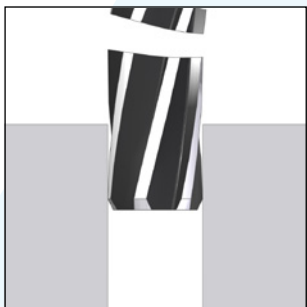

Reamer jams and breaks | Problems

- // Cylindrical grinding phase too wide
- // Cutting edge not conical enough
- // Predrilled hole too small and not centered
- // Angle of cut poorly ground

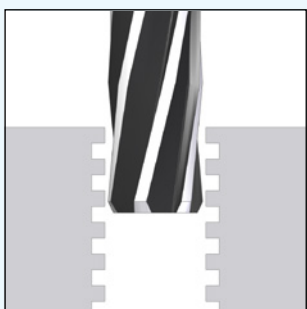

Hole shows chatter marks | Problems

- // Insufficient workpiece clamping
- // Too high cutting speed
- // Too low feed rate

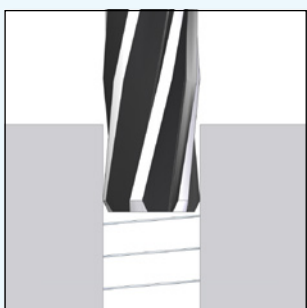

Retention marks in hole | Problems

- // Depth of cut
- // Use a sharper geometry
- // Pull back feed too high

ER floating chucks

When using reamers on lathes it is often necessary to compensate for axis error between the chuck and the bore to be machined. This error can be corrected by using a self-centering floating chuck.

PH/PHC/PHC-C/MPH/MPHC

Features and benefits

Adjustable floating resistance

Continuously adjustable between auto-centering and free-floating. No restriction of the floating movement.

Adjustment for tool weight

Optimal setup by adjustment of floating resistance is possible.

Vertical and horizontal application

Adjustable self-centering keeps the tool at the center of the floating chuck, even in the horizontal position. Prevents chatter marks and extends tool life.

Combined ball- and friction-bearing

Combined ball and friction-bearing for easy floating:

- // Ball bearing for smooth reaming at low load applications
- // Friction-bearing to withstand high pressures at high load applications

Double sealing against dirt

Prevents coolant and chips from entering the floating chuck.

Excellent bore quality

Only parallel floatation of tool possible.

Floating chuck PH/ER

Features REGO-FIX floating chucks are excellent tools for reaming and tapping:

- // They are specially designed so the tool is self-centering in a vertical and horizontal position
- // The self-centering feature allows very precise positioning of the reaming or tapping tool. This is especially important in horizontal applications, where on ordinary floating chucks the weight of the tool tends to dislocate the tool from the rotational axis
- // The float is always parallel to the rotational axis and the rotation is both clockwise and counter clockwise

Floating chuck PHC/ER for coolant through tools

Features Floating chucks PHC/ER for coolant through tools are especially designed for internal cooling and have the same advantages as the PH/ER floating chucks.

Floating chuck PHC-C/ER REGO-FIX CAPTO

Features These REGO-FIX CAPTO floating chucks are manufactured with polygon interface – licensed by Sandvik Coromant.

Floating chuck MPH/ERMX for tight spaces

Features REGO-FIX MPH/ERMX floating chucks are an efficient solution for tight space applications.

MPHC/ERMXC for tight spaces with internal cooling

Features The MPHC floating chuck is the mini version with internal cooling, common with modern reaming applications.

PH floating chucks for non coolant through tools

PH

Type	Part no.	Dimensions [mm]						Accessories	
		BD1	DCONMS h6	BD2	OHN	LS	RFI	Wrench	
PH 5/8 [inch]									
PH 5/8" /ERAX 11	2616.91102	22	15,88	38	36	34	0,8	7117.11000	
PH 16 [mm]									
PH 16/ERAX 11	2616.91100	22	16	38	36	34	0,8	7117.11000	
PH 3/4 [inch]									
PH 3/4" /ERAX 11	2619.91102	22	19,05	38	36	34	0,8	7117.11000	
PH 20 [mm]									
PH 20/ERAX 11	2620.91100	22	20	38	36	34	0,8	7117.11000	

Included in delivery: Floating holder comes with Hi-Q®|ER clamping nut and wrench



Expert advice

In a conventional floating chuck, the centering of the tool. This centering process causes tool wear and can even lead to tool breakage.

The REGO-FIX floating chuck has an axis-parallel pendulum function that is self-centering. As a result, the tool is stable in the gating phase and no trumpet-shaped bore is created.

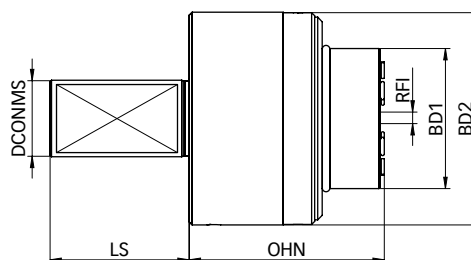

PH + PHC/ERAX

PHC floating chucks for coolant through tools

PHC

Type	Part no.	Dimensions [mm]					Accessories	
		BD1	DCONMS h6	BD2	OHN	LS	RFI	Wrench
PHC 5/8 [inch]								
PHC 5/8" /ERAX 20	2616.92004	33	15,88	56	53,5	38	1	7117.20000
PHC 16 [mm]								
PHC 16/ERAX 20	2616.92003	33	16	56	53,5	38	1	7117.20000
PHC 3/4 [inch]								
PHC 3/4" /ERAX 20	2619.92004	33	19,05	56	53,5	38	1	7117.20000
PHC 3/4" /ERAX 32	2619.93204	46	19,05	70	64,5	46	1,5	7117.32000
PHC 20 [mm]								
PHC 20/ERAX 20	2620.92003	33	20	56	53,5	38	1	7117.20000
PHC 20/ERAX 32	2620.93203	46	20	70	64,5	46	1,5	7117.32000
PHC 22 [mm]								
PHC 22/ERAX 20	2622.92003	33	22	56	53,5	38	1	7117.20000
PHC 25 [mm]								
PHC 25/ERAX 20	2625.92003	33	25	56	53,5	38	1	7117.20000
PHC 25/ERAX 32	2625.93203	46	25	70	64,5	46	1,5	7117.32000
PHC 1 [inch]								
PHC 1" /ERAX 20	2625.92004	33	25,4	56	53,5	38	1	7117.20000
PHC 1" /ERAX 32	2625.93204	46	25,4	70	64,5	46	1,5	7117.32000
PHC 1 1/4 [inch]								
PHC 1 1/4" /ERAX 32	2632.93204	46	31,75	70	64,5	46	1,5	7117.32000
PHC 32 [mm]								
PHC 32/ERAX 32	2632.93203	46	32	70	64,5	46	1,5	7117.32000

Included in delivery: Floating holder comes with Hi-Q®|ERAX clamping nut, wrench and adjusting key

Expert advice

When using coolant through tools please order Hi-Q®|ERAXC clamping nuts and the corresponding sealing disks.

PHC floating chucks for coolant through tools with REGO-FIX CAPTO interface

PHC-C

Type	Part no.	Dimensions [mm]			Accessories	
		BD1	BD2	LPR	RFI	Wrench
PHC C3						
PHC C3/ERAX 20	2803.92003	33	56	91	0,8	7117.20000
PHC C4						
PHC C4/ERAX 20	2804.92003	33	56	91	0,8	7117.20000
PHC C4/ERAX 32	2804.93203	46	70	100	0,8	7117.32000

Included in delivery: Floating holder comes with Hi-Q®|ERAX clamping nut and wrench

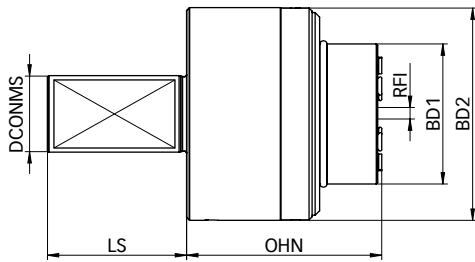

PHC/ERAX

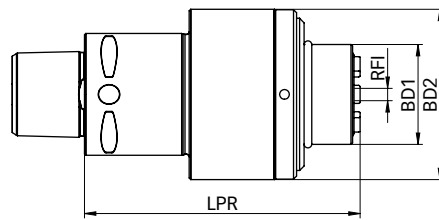

PHC C/ERAX

Certified REGO-FIX CAPTO – licensed by Sandvik Coromant – is manufactured at REGO-FIX Switzerland under license according to CAPTO specifications.

MPH mini floating chucks with intRlox®

MPH

(slip-off proof mini clamping nut)

Type	Part no.	Dimensions [mm]					Accessories	
		DLN	DCONMS h6	BD2	OHN	LS	RFI	Wrench
MPH 8 [mm]								
MPH 8/ERMX 11	4608.91107	16	8	25	35,5	42	0,5	7118.11000
MPH 10 [mm]								
MPH 10/ERMX 11	4610.91107	16	10	25	35,5	42	0,5	7118.11000
MPH 16 [mm]								
MPH 16/ERMX 11	4616.91107	16	16	25	35,5	42	0,5	7118.11000
MPH 3/4 [inch]								
MPH 3/4" /ERMX 11	4619.91108	16	19,05	25	35,5	70	0,5	7118.11000
MPH 20 [mm]								
MPH 20/ERMX 11	4620.91107	16	20	25	35,5	42	0,5	7118.11000
MPH 22 [mm]								
MPH 22/ERMX 11	4622.91107	16	22	25	35,5	42	0,5	7118.11000
MPH 25 [mm]								
MPH 25/ERMX 11	4625.91107	16	25	25	35,5	42	0,5	7118.11000
MPH 1 [inch]								
MPH 1" /ERMX 11	4625.91108	16	25,4	25	35,5	42	0,5	7118.11000

Included in delivery: Floating holder comes with Hi-Q®|ERMX clamping nut and wrench

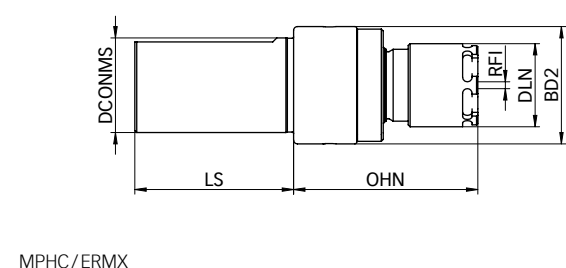

MPHC mini floating chucks with intRlox®

MPHC

(slip-off proof mini clamping nut)

Type	Part no.	Dimensions [mm]						Accessories	
		DLN	DCONMS h6	BD2	OHN	LS	RFI	Wrench	
MPHC 8 [mm]									
MPHC 8/ERMX 11	4608.91105	16	8	25	35,5	42	0,5	7118.11000	
MPHC 10 [mm]									
MPHC 10/ERMX 11	4610.91105	16	10	25	35,5	42	0,5	7118.11000	
MPHC 10/ERMX 16	4610.91605	22	10	31	48,7	42	0,5	7118.16000	
MPHC 16 [mm]									
MPHC 16/ERMX 16	4616.91605	22	16	31	48,7	42	0,5	7118.16000	
MPHC 3/4 [inch]									
MPHC 3/4"/ERMX 11	4619.91106	16	19,05	25	35,5	42	0,5	7118.11000	
MPHC 3/4"/ERMX 16	4619.91606	22	19,05	31	48,7	42	0,5	7118.16000	
MPHC 20 [mm]									
MPHC 20/ERMX 11	4620.91105	16	20	25	35,5	42	0,5	7118.11000	
MPHC 20/ERMX 16	4620.91605	22	20	31	48,7	42	0,5	7118.16000	
MPHC 22 [mm]									
MPHC 22/ERMX 16	4622.91605	22	22	31	48,7	42	0,5	7118.16000	
MPHC 25 [mm]									
MPHC 25/ERMX 16	4625.91605	22	25	31	48,7	42	0,5	7118.16000	
MPHC 1 [inch]									
MPH 1"/ERMX 16	4625.91606	22	25,4	31	48,7	42	0,5	7118.16000	
Type	Part no.	DLN	SW	BD2	L	LPR	RFI	Wrench	
MPHC WTO ER ADP									
MPHC WTO ER 25-QF/ERMX 11	8040.25115	16	–	49,5	–	24	0.5	7118.16000	
MPHC WTO ER 32-QF/ERMX 16	8040.32165	22	–	58	–	33	0.5	7118.16000	

Included in delivery: Mini holder, Hi-Q® / ERMX nut and wrench

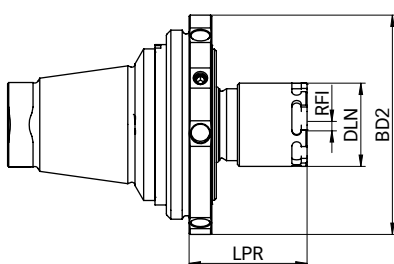

MPHC WTO ER-QF/ERMX

Assembly instructions for ER and MR collets

Collets ER 11–ER 50 and MR 11–MR 32 (with collet locking system)

Assembling Insert groove of the collet into eccentric ring of the clamping nut at the mark on the bottom of the nut. Push collet in the direction of the arrow until it clicks in. Insert tool. Screw nut with collet onto toolholder.

Disassembling After the nut is unscrewed from the toolholder, press on the face of the collet while simultaneously pushing sideways on the back of the collet opposite the mark until it disengages from the clamping nut.

Important Improper assembly can permanently damage the runout TIR of the collet and may result in the destruction of the clamping nut. Only mount nuts with correctly inserted collets. Never place the collet into the holder without first assembling into the nut.

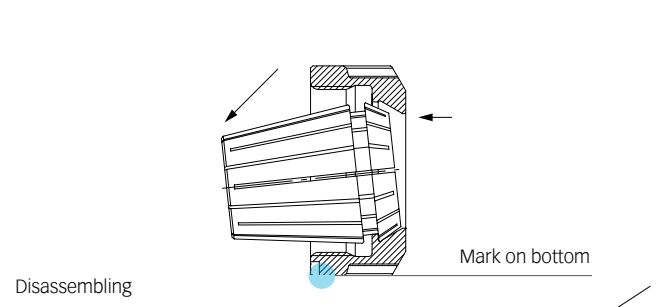
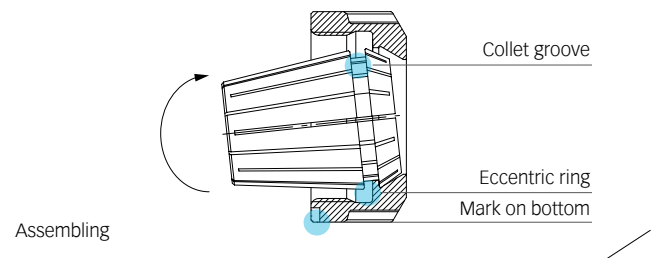

Collets ER 8 (without collet locking system)

Assembling Insert groove of the collet into eccentric ring of the clamping nut at the mark on the bottom of the nut. Insert tool. Hold nut with collet in horizontal position and screw onto toolholder.

Disassembling After unscrewing the clamping nut from the tool holder, the collet can easily be removed from the clamping nut.

Important The face of the ER 8 collet chuck must fit cleanly against the inner surface of the clamping nut. (ER 8 collets do not feature a 30° cone.)

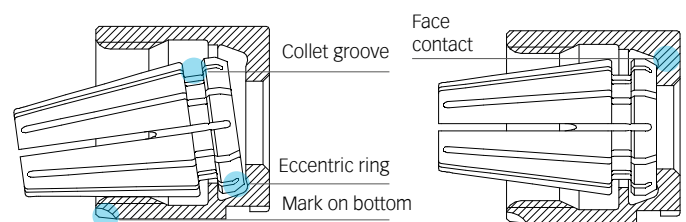
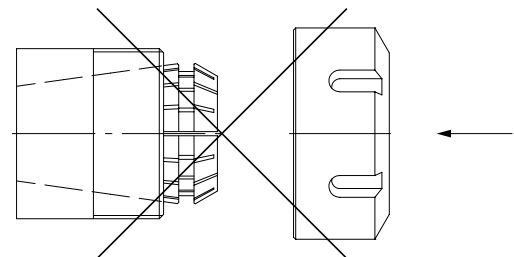

Expert advice

Never insert the tool less than $\frac{2}{3}$ of the collet length. We recommend tightening the clamping nuts with our TORCO-BLOCK or torque wrench.

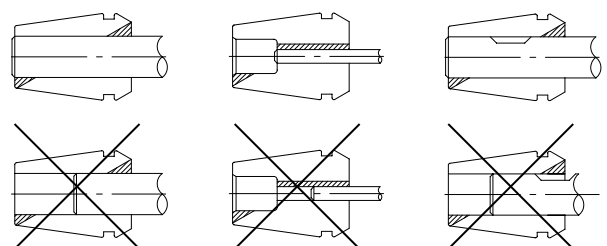

ER standard collets and ultraprecision collets ER-UP

ER std.	ER-UP
DIN 6499-B	DIN 6499-B
ISO 15488	ISO 15488

Type	Part no.		Clamping range		Ø [inch]	Included in set
	ER standard	ER-UP	[mm]	[decimal inch]		
ER 8 [mm]						
SET ER 8	1108.00000	1108.00001	0,5–5,0	0,0197–0,1969	–	–
Ø 1,0 mm	1108.01000	1108.01001	1,0–0,5	0,0394–0,0197	1/32"	•
Ø 1,25 mm	1108.01250	–	1,25–0,75	0,0492–0,0295	–	–
Ø 1,5 mm	1108.01500	1108.01501	1,5–1,0	0,0591–0,0394	–	•
Ø 1,75 mm	1108.01750	–	1,75–1,25	0,0688–0,0492	–	–
Ø 2,0 mm	1108.02000	1108.02001	2,0–1,5	0,0787–0,0591	1/16"*	•
Ø 2,25 mm	1108.02250	–	2,25–1,75	0,0885–0,0688	–	–
Ø 2,5 mm	1108.02500	1108.02501	2,5–2,0	0,0984–0,0787	3/32"	•
Ø 3,0 mm	1108.03000	1108.03001	3,0–2,5	0,1181–0,0984	–	•
Ø 3,5 mm	1108.03500	1108.03501	3,5–3,0	0,1378–0,1181	1/8"*	•
Ø 4,0 mm	1108.04000	1108.04001	4,0–3,5	0,1575–0,1378	5/32"	•
Ø 4,5 mm	1108.04500	1108.04501	4,5–4,0	0,1772–0,1575	–	•
Ø 5,0 mm	1108.05000	1108.05001	5,0–4,5	0,1969–0,1772	3/16"*	•
ER 8 [inch]						
INCH SET ER 8	1108.00002	1108.00003	1,09–4,76	0,0429–0,1875	–	–
Ø 1/16"	1108.01592	1108.01593	1,59–1,09	0,0625–0,0429	–	•
Ø 1/8"	1108.03182	1108.03183	3,18–2,68	0,125–0,1055	–	•
Ø 3/16"	1108.04762	1108.04763	4,76–4,25	0,1875–0,1675	–	•
ER 11 [mm]						
SET ER 11	1111.00000	1111.00001	0,5–7,0	0,0197–0,2756	–	–
Ø 1,0 mm	1111.01000	1111.01001	1,0–0,5	0,0394–0,0197	1/32"	•
Ø 1,25 mm	1111.01250	–	1,25–0,75	0,0492–0,0295	–	–
Ø 1,5 mm	1111.01500	1111.01501	1,5–1,0	0,0591–0,0394	–	•
Ø 1,75 mm	1111.01750	–	1,75–1,25	0,0688–0,0492	–	–
Ø 2,0 mm	1111.02000	1111.02001	2,0–1,5	0,0787–0,0591	1/16"*	•
Ø 2,25 mm	1111.02250	–	2,25–1,75	0,0885–0,0688	–	–
Ø 2,5 mm	1111.02500	1111.02501	2,5–2,0	0,0984–0,0787	3/32"*	•
Ø 3,0 mm	1111.03000	1111.03001	3,0–2,5	0,1181–0,0984	–	•
Ø 3,5 mm	1111.03500	1111.03501	3,5–3,0	0,1378–0,1181	1/8"*	•
Ø 4,0 mm	1111.04000	1111.04001	4,0–3,5	0,1575–0,1378	5/32"*	•
Ø 4,5 mm	1111.04500	1111.04501	4,5–4,0	0,1772–0,1575	–	•
Ø 5,0 mm	1111.05000	1111.05001	5,0–4,5	0,1969–0,1772	3/16"*	•
Ø 5,5 mm	1111.05500	1111.05501	5,5–5,0	0,2165–0,1969	–	•
Ø 6,0 mm	1111.06000	1111.06001	6,0–5,5	0,2362–0,2165	7/32"*	•
Ø 6,0 mm – ND	1111.06005	–	h11	0,2362	–	–
Ø 6,5 mm	1111.06500	1111.06501	6,5–6,0	0,2559–0,2362	1/4"*	•
Ø 7,0 mm	1111.07000	1111.07001	7,0–6,5	0,2756–0,2559	–	•

Included in the ER sets are all marked collets within that size and the matching collet tray ZWT

*Approx. inch sizing

ER standard collets and ultraprecision collets ER-UP

ER std.	ER-UP
DIN 6499-B	DIN 6499-B
ISO 15488	ISO 15488

Type	Part no.		Clamping range		Ø [inch]	Included in set
	ER standard	ER-UP	[mm]	[decimal inch]		
ER 11 [inch]						
INCH SET ER 11	1111.00002	1111.00003	1,09–6,35	0,0429–0,25	–	–
Ø 1/16"	1111.01592	1111.01593	1,59–1,09	0,0625–0,0429	1/16"	•
Ø 3/32"	1111.02382	1111.02383	2,38–1,87	0,0938–0,0738	3/32"	•
Ø 1/8"	1111.03182	1111.03183	3,18–2,67	0,125–0,105	1/8"	•
Ø 5/32"	1111.03972	1111.03973	3,97–3,46	0,1563–0,1363	5/32"	•
Ø 3/16"	1111.04762	1111.04763	4,76–4,25	0,1875–0,1675	3/16"	•
Ø 7/32"	1111.05562	1111.05563	5,56–5,04	0,2188–0,1988	7/32"	•
Ø 1/4"	1111.06352	1111.06353	6,35–5,84	0,25–0,23	1/4"	•

ER 16 [mm]						
SET ER 16	1116.00000	1116.00001	0,5–10,0	0,0197–0,3937	–	–
Ø 1,0 mm	1116.01000	1116.01001	1,0–0,5	0,0394–0,0197	1/32"	•
Ø 1,5 mm	1116.01500	1116.01501	1,5–1,0	0,0591–0,0394	–	–
Ø 2,0 mm	1116.02000	1116.02001	2,0–1,0	0,0787–0,0394	1/16"*	•
Ø 2,5 mm	1116.02500	1116.02501	2,5–1,5	0,0984–0,0591	3/32"*	–
Ø 3,0 mm	1116.03000	1116.03001	3,0–2,0	0,1181–0,0787	–	•
Ø 3,5 mm	1116.03500	1116.03501	3,5–2,5	0,1378–0,0984	1/8"*	–
Ø 4,0 mm	1116.04000	1116.04001	4,0–3,0	0,1575–0,1181	5/32"*	•
Ø 4,5 mm	1116.04500	1116.04501	4,5–3,5	0,1772–0,1378	–	–
Ø 5,0 mm	1116.05000	1116.05001	5,0–4,0	0,1969–0,1575	3/16"*	•
Ø 5,5 mm	1116.05500	1116.05501	5,5–4,5	0,2165–0,1772	–	–
Ø 6,0 mm	1116.06000	1116.06001	6,0–5,0	0,2362–0,1969	7/32"*	•
Ø 6,5 mm	1116.06500	1116.06501	6,5–5,5	0,2559–0,2165	1/4"*	–
Ø 7,0 mm	1116.07000	1116.07001	7,0–6,0	0,2756–0,2362	–	•
Ø 7,5 mm	1116.07500	1116.07501	7,5–6,5	0,2953–0,2559	9/32"*	–
Ø 8,0 mm	1116.08000	1116.08001	8,0–7,0	0,315–0,2756	5/16"*	•
Ø 8,5 mm	1116.08500	1116.08501	8,5–7,5	0,3346–0,2953	–	–
Ø 9,0 mm	1116.09000	1116.09001	9,0–8,0	0,3543–0,315	11/32"*	•
Ø 9,5 mm	1116.09500	1116.09501	9,5–8,5	0,374–0,3346	–	–
Ø 10,0 mm	1116.10000	1116.10001	10,0–9,0	0,3937–0,3543	3/8"*	•

ER 16 [inch]						
INCH SET ER 16	1116.00002	1116.00003	1,09–10,32	0,0429–0,4063	–	–
Ø 1/16"	1116.01592	1116.01593	1,59–1,09	0,0625–0,0429	1/16"	•
Ø 3/32"	1116.02382	1116.02383	2,38–1,87	0,0938–0,0738	3/32"	•
Ø 1/8"	1116.03182	1116.03183	3,18–2,16	0,125–0,085	1/8"	•
Ø 5/32"	1116.03972	1116.03973	3,97–2,95	0,1563–0,1163	5/32"	•
Ø 3/16"	1116.04762	1116.04763	4,76–3,75	0,1875–0,1475	3/16"	•
Ø 7/32"	1116.05562	1116.05563	5,56–4,54	0,2188–0,1788	7/32"	•

Included in the ER sets are all marked collets within that size and the matching collet tray ZWT

*Approx. inch sizing

ER standard collets and ultraprecision collets ER-UP

ER std.	ER-UP
DIN 6499-B	DIN 6499-B
ISO 15488	ISO 15488

Type	Part no.		Clamping range		Ø [inch]	Included in set
	ER standard	ER-UP	[mm]	[decimal inch]		
Ø 1/4"	1116.06352	1116.06353	6,35–5,33	0,25–0,21	1/4"	•
Ø 9/32"	1116.07142	1116.07143	7,15–6,13	0,2813–0,2413	9/32"	•
Ø 5/16"	1116.07942	1116.07943	7,94–6,92	0,3125–0,2725	5/16"	•
Ø 11/32"	1116.08732	1116.08733	8,73–7,72	0,3438–0,3038	11/32"	•
Ø 3/8"	1116.09532	1116.09533	9,53–8,51	0,375–0,335	3/8"	•
Ø 13/32"	1116.10322	1116.10323	10,32–9,3	0,4063–0,3663	13/32"	•

ER 20 [mm]						
SET ER 20	1120.00000	1120.00001	1,0–13,0	0,0394–0,5118	–	–
Ø 1,0 mm	1120.01000	1120.01001	1,0–0,5	0,0394–0,0197	1/32"	–
Ø 1,5 mm	1120.01500	1120.01501	1,5–1,0	0,0591–0,0394	–	–
Ø 2,0 mm	1120.02000	1120.02001	2,0–1,0	0,0787–0,0394	1/16"	•
Ø 2,5 mm	1120.02500	1120.02501	2,5–1,5	0,0984–0,0591	3/32"	–
Ø 3,0 mm	1120.03000	1120.03001	3,0–2,0	0,1181–0,0787	–	•
Ø 3,5 mm	1120.03500	1120.03501	3,5–2,5	0,1378–0,0984	1/8"	–
Ø 4,0 mm	1120.04000	1120.04001	4,0–3,0	0,1575–0,1181	5/32"	•
Ø 4,5 mm	1120.04500	1120.04501	4,5–3,5	0,1772–0,1378	–	–
Ø 5,0 mm	1120.05000	1120.05001	5,0–4,0	0,1969–0,1575	3/16"	•
Ø 5,5 mm	1120.05500	1120.05501	5,5–4,5	0,2165–0,1772	–	–
Ø 6,0 mm	1120.06000	1120.06001	6,0–5,0	0,2362–0,1969	7/32"	•
Ø 6,5 mm	1120.06500	1120.06501	6,5–5,5	0,2559–0,2165	1/4"	–
Ø 7,0 mm	1120.07000	1120.07001	7,0–6,0	0,2756–0,2362	–	•
Ø 7,5 mm	1120.07500	1120.07501	7,5–6,5	0,2953–0,2559	9/32"	–
Ø 8,0 mm	1120.08000	1120.08001	8,0–7,0	0,315–0,2756	5/16"	•
Ø 8,5 mm	1120.08500	1120.08501	8,5–7,5	0,3346–0,2953	–	–
Ø 9,0 mm	1120.09000	1120.09001	9,0–8,0	0,3543–0,315	11/32"	•
Ø 9,5 mm	1120.09500	1120.09501	9,5–8,5	0,374–0,3346	–	–
Ø 10,0 mm	1120.10000	1120.10001	10,0–9,0	0,3937–0,3543	3/8"	•
Ø 10,5 mm	1120.10500	1120.10501	10,5–9,5	0,4134–0,374	13/32"	–
Ø 11,0 mm	1120.11000	1120.11001	11,0–10,0	0,4331–0,3937	–	•
Ø 11,5 mm	1120.11500	1120.11501	11,5–10,5	0,4528–0,4134	7/16"	–
Ø 12,0 mm	1120.12000	1120.12001	12,0–11,0	0,4724–0,433	15/32"	•
Ø 12,5 mm	1120.12500	1120.12501	12,5–11,5	0,4921–0,4528	–	–
Ø 13,0 mm	1120.13000	1120.13001	13,0–12,0	0,5118–0,4724	1/2"	•

Included in the ER sets are all marked collets within that size and the matching collet tray ZWT

*Approx. inch sizing

ER standard collets and ultraprecision collets ER-UP

ER std.	ER-UP
DIN 6499-B	DIN 6499-B
ISO 15488	ISO 15488

Type	Part no.		Clamping range		Ø [inch]	Included in set
	ER standard	ER-UP	[mm]	[decimal inch]		
ER 20 [inch]						
INCH SET ER 20	1120.00002	1120.00003	2,16–12,7	0,085–0,5	–	–
Ø 1/8"	1120.03182	1120.03183	3,18–2,18	0,125–0,085	1/8"	•
Ø 3/16"	1120.04762	1120.04763	4,76–3,76	0,1875–0,1475	3/16"	•
Ø 1/4"	1120.06352	1120.06353	6,35–5,35	0,25–0,21	1/4"	•
Ø 5/16"	1120.07942	1120.07943	7,94–6,94	0,3125–0,2725	5/16"	•
Ø 3/8"	1120.09532	1120.09533	9,53–8,53	0,375–0,335	3/8"	•
Ø 7/16"	1120.11112	1120.11113	11,11–10,11	0,4375–0,3975	7/16"	•
Ø 1/2"	1120.12702	1120.12703	12,7–11,7	0,5–0,46	1/2"	•
ER 25 [mm]						
SET ER 25	1125.00000	1125.00001	2,0–16,0	0,0787–0,6299	–	–
Ø 1,0 mm	1125.01000	1125.01001	1,0–0,5	0,0394–0,0197	1/32"	–
Ø 1,5 mm	1125.01500	1125.01501	1,5–1,0	0,0591–0,0394	–	–
Ø 2,0 mm	1125.02000	1125.02001	2,0–1,0	0,0787–0,0394	1/16"	•
Ø 2,5 mm	1125.02500	1125.02501	2,5–1,5	0,0984–0,0591	3/32"	–
Ø 3,0 mm	1125.03000	1125.03001	3,0–2,0	0,1181–0,0787	–	•
Ø 3,5 mm	1125.03500	1125.03501	3,5–2,5	0,1378–0,0984	1/8"*	–
Ø 4,0 mm	1125.04000	1125.04001	4,0–3,0	0,1575–0,1181	5/32"	•
Ø 4,5 mm	1125.04500	1125.04501	4,5–3,5	0,1772–0,1378	–	–
Ø 5,0 mm	1125.05000	1125.05001	5,0–4,0	0,1969–0,1575	3/16"*	•
Ø 5,5 mm	1125.05500	1125.05501	5,5–4,5	0,2165–0,1772	–	–
Ø 6,0 mm	1125.06000	1125.06001	6,0–5,0	0,2362–0,1969	7/32"	•
Ø 6,5 mm	1125.06500	1125.06501	6,5–5,5	0,2559–0,2165	1/4"*	–
Ø 7,0 mm	1125.07000	1125.07001	7,0–6,0	0,2756–0,2362	–	•
Ø 7,5 mm	1125.07500	1125.07501	7,5–6,5	0,2953–0,2559	9/32"	–
Ø 8,0 mm	1125.08000	1125.08001	8,0–7,0	0,315–0,2756	5/16"*	•
Ø 8,5 mm	1125.08500	1125.08501	8,5–7,5	0,3346–0,2953	–	–
Ø 9,0 mm	1125.09000	1125.09001	9,0–8,0	0,3543–0,315	11/32"	•
Ø 9,5 mm	1125.09500	1125.09501	9,5–8,5	0,374–0,3346	–	–
Ø 10,0 mm	1125.10000	1125.10001	10,0–9,0	0,3937–0,3543	3/8"*	•
Ø 10,5 mm	1125.10500	1125.10501	10,5–9,5	0,4134–0,374	13/32"	–
Ø 11,0 mm	1125.11000	1125.11001	11,0–10,0	0,4331–0,3937	–	•
Ø 11,5 mm	1125.11500	1125.11501	11,5–10,5	0,4528–0,4134	7/16"*	–
Ø 12,0 mm	1125.12000	1125.12001	12,0–11,0	0,4724–0,4331	15/32"	•
Ø 12,5 mm	1125.12500	1125.12501	12,5–11,5	0,4921–0,4528	–	–
Ø 13,0 mm	1125.13000	1125.13001	13,0–12,0	0,5118–0,4724	1/2"*	•
Ø 13,5 mm	1125.13500	1125.13501	13,5–12,5	0,5315–0,4921	17/32"	–
Ø 14,0 mm	1125.14000	1125.14001	14,0–13,0	0,5512–0,5118	–	•
Ø 14,5 mm	1125.14500	1125.14501	14,5–13,5	0,5709–0,5315	9/16"*	–
Ø 15,0 mm	1125.15000	1125.15001	15,0–14,0	0,5906–0,5512	–	•
Ø 15,5 mm	1125.15500	1125.15501	15,5–14,5	0,6102–0,5709	19/32"	–
Ø 16,0 mm	1125.16000	1125.16001	16,0–15,0	0,6299–0,5905	5/8"*	•
Ø 17,0 mm	1125.17000	1125.17001	17,0–16,0	0,6693–0,6299	21/32"	–

ER standard collets and ultraprecision collets ER-UP

ER std.	ER-UP
DIN 6499-B	DIN 6499-B
ISO 15488	ISO 15488

Type	Part no.		Clamping range		Ø [inch]	Included in set
	ER standard	ER-UP	[mm]	[decimal inch]		
ER 25 [inch]						
INCH SET ER 25	1125.00002	1125.00003	2,16–15,88	0,085–0,625	–	–
Ø 1/8"	1125.03182	1125.03183	3,18–2,16	0,125–0,085	1/8"	•
Ø 3/16"	1125.04762	1125.04763	4,76–3,75	0,1875–0,1475	3/16"	•
Ø 1/4"	1125.06352	1125.06353	6,35–5,33	0,25–0,21	1/4"	•
Ø 5/16"	1125.07942	1125.07943	7,94–6,92	0,3125–0,2725	5/16"	•
Ø 3/8"	1125.09532	1125.09533	9,53–8,51	0,375–0,335	3/8"	•
Ø 7/16"	1125.11112	1125.11113	11,11–10,11	0,4375–0,3975	7/16"	•
Ø 1/2"	1125.12702	1125.12703	12,70–11,68	0,5–0,46	1/2"	•
Ø 9/16"	1125.14292	1125.14293	14,29–13,27	0,5625–0,5225	9/16"	•
Ø 5/8"	1125.15882	1125.15883	15,88–14,78	0,625–0,582	5/8"	•
ER 32 [mm]						
SET ER 32	1132.00000	1132.00001	2,0–20,0	0,0787–0,7874	–	–
Ø 2,0 mm	1132.02000	1132.02001	2,0–1,0	0,0787–0,0394	1/16"	–
Ø 2,5 mm	1132.02500	1132.02501	2,5–1,5	0,0984–0,0591	3/32"	–
Ø 3,0 mm	1132.03000	1132.03001	3,0–2,0	0,1181–0,0787	–	•
Ø 3,5 mm	1132.03500	1132.03501	3,5–2,5	0,1378–0,0984	1/8"*	–
Ø 4,0 mm	1132.04000	1132.04001	4,0–3,0	0,1575–0,1181	5/32"	•
Ø 4,5 mm	1132.04500	1132.04501	4,5–3,5	0,1772–0,1378	–	–
Ø 5,0 mm	1132.05000	1132.05001	5,0–4,0	0,1969–0,1575	3/16"*	•
Ø 5,5 mm	1132.05500	1132.05501	5,5–4,5	0,2165–0,1772	–	–
Ø 6,0 mm	1132.06000	1132.06001	6,0–5,0	0,2362–0,1969	7/32"	•
Ø 6,5 mm	1132.06500	1132.06501	6,5–5,5	0,2559–0,2165	1/4"*	–
Ø 7,0 mm	1132.07000	1132.07001	7,0–6,0	0,2756–0,2362	–	•
Ø 7,5 mm	1132.07500	1132.07501	7,5–6,5	0,2953–0,2559	9/32"	–
Ø 8,0 mm	1132.08000	1132.08001	8,0–7,0	0,315–0,2756	5/16"*	•
Ø 8,5 mm	1132.08500	1132.08501	8,5–7,5	0,3346–0,2953	–	–
Ø 9,0 mm	1132.09000	1132.09001	9,0–8,0	0,3543–0,315	11/32"	•
Ø 9,5 mm	1132.09500	1132.09501	9,5–8,5	0,374–0,3346	–	–
Ø 10,0 mm	1132.10000	1132.10001	10,0–9,0	0,3937–0,3543	3/8"*	•
Ø 10,5 mm	1132.10500	1132.10501	10,5–9,5	0,4134–0,374	13/32"	–
Ø 11,0 mm	1132.11000	1132.11001	11,0–10,0	0,4331–0,3937	–	•
Ø 11,5 mm	1132.11500	1132.11501	11,5–10,5	0,4528–0,4134	7/16"*	–
Ø 12,0 mm	1132.12000	1132.12001	12,0–11,0	0,4724–0,4331	15/32"	•
Ø 12,5 mm	1132.12500	1132.12501	12,5–11,5	0,4921–0,4528	–	–
Ø 13,0 mm	1132.13000	1132.13001	13,0–12,0	0,5118–0,4724	1/2"*	•
Ø 13,5 mm	1132.13500	1132.13501	13,5–12,5	0,5315–0,4921	17/32"	–
Ø 14,0 mm	1132.14000	1132.14001	14,0–13,0	0,5512–0,5118	–	•
Ø 14,5 mm	1132.14500	1132.14501	14,5–13,5	0,5709–0,5315	9/16"*	–
Ø 15,0 mm	1132.15000	1132.15001	15,0–14,0	0,5906–0,5512	–	•
Ø 15,5 mm	1132.15500	1132.15501	15,5–14,5	0,6102–0,5709	19/32"	–
Ø 16,0 mm	1132.16000	1132.16001	16,0–15,0	0,63299–0,5906	5/8"*	•
Ø 16,5 mm	1132.16500	1132.16501	16,5–15,5	0,6496–0,6102	–	–

Included in the ER sets are all marked collets within that size and the matching collet tray ZWT

*Approx. inch sizing

ER standard collets and ultraprecision collets ER-UP

ER std.	ER-UP
DIN 6499-B	DIN 6499-B
ISO 15488	ISO 15488

Type	Part no.		Clamping range		Ø [inch]	Included in set
	ER standard	ER-UP	[mm]	[decimal inch]		
ER 32 [mm] continued						
Ø 17,0 mm	1132.17000	1132.17001	17,0 – 16,0	0,6693 – 0,6299	21/32"	•
Ø 17,5 mm	1132.17500	1132.17501	17,5 – 16,5	0,689 – 0,6496	11/16"*	–
Ø 18,0 mm	1132.18000	1132.18001	18,0 – 17,0	0,7087 – 0,6693	–	•
Ø 18,5 mm	1132.18500	1132.18501	18,5 – 17,5	0,7283 – 0,689	23/32"	–
Ø 19,0 mm	1132.19000	1132.19001	19,0 – 18,0	0,748 – 0,7078	–	•
Ø 19,5 mm	1132.19500	1132.19501	19,5 – 18,5	0,7677 – 0,7284	3/4"*	–
Ø 20,0 mm	1132.20000	1132.20001	20,0 – 19,0	0,7874 – 0,748	25/32"	•
Ø 21,0 mm	1132.21000	1132.21001	21,0 – 20,0	0,8268 – 0,7874	13/16"*	–
Ø 22,0 mm	1132.22000	1132.22001	22,0 – 21,0	0,8661 – 0,8268	–	–

ER 32 [inch]						
INCH SET ER 32	1132.00002	1132.00003	2,16 – 20,64	0,085 – 0,8125	–	–
Ø 1/8"	1132.03182	1132.03183	3,18 – 2,16	0,125 – 0,085	1/8"	•
Ø 3/16"	1132.04762	1132.04763	4,76 – 3,75	0,1875 – 0,1475	3/16"	•
Ø 1/4"	1132.06352	1132.06353	6,35 – 5,33	0,25 – 0,21	1/4"	•
Ø 5/16"	1132.07942	1132.07943	7,94 – 6,92	0,3125 – 0,2725	5/16"	•
Ø 3/8"	1132.09532	1132.09533	9,53 – 8,51	0,375 – 0,335	3/8"	•
Ø 7/16"	1132.11112	1132.11113	11,11 – 10,1	0,4375 – 0,3975	7/16"	•
Ø 1/2"	1132.12702	1132.12703	12,7 – 11,68	0,5 – 0,46	1/2"	•
Ø 9/16"	1132.14292	1132.14293	14,29 – 13,27	0,5625 – 0,5225	9/16"	•
Ø 5/8"	1132.15882	1132.15883	15,88 – 14,86	0,625 – 0,585	5/8"	•
Ø 11/16"	1132.17462	1132.17463	17,46 – 16,45	0,6875 – 0,6475	11/16"	•
Ø 3/4"	1132.19052	1132.19053	19,05 – 18,03	0,75 – 0,71	3/4"	•
Ø 13/16"	1132.20642	1132.20643	20,64 – 19,62	0,8125 – 0,7725	13/16"	•

Type	Part no.	Clamping range		Ø [inch]	Included in set
		[mm]	[decimal inch]		
ER 11-DM [mm]					
Ø 3,0 mm	1211.03000	3,0–2,75	0,1181–0,1083	–	–
Ø 4,0 mm	1211.04000	4,0–3,75	0,1575–0,1476	–	–
Ø 5,0 mm	1211.05000	5,0–4,75	0,1969–0,187	–	–
Ø 6,0 mm	1211.06000	6,0–5,75	0,2362–0,2264	–	–
Ø 7,0 mm	1211.07000	7,0–6,75	0,2756–0,2657	–	–
ER 11-DM [inch]					
Ø 1/8"	1211.03182	3,18–2,93	0,125–0,1154	1/8"	–
Ø 3/16"	1211.04762	4,76–4,51	0,1875–0,1776	3/16"	–
Ø 7/32"	1211.05562	5,56–5,31	0,2188–0,2091	7/32"	–
Ø 1/4"	1211.06352	6,35–6,1	0,25–0,2402	1/4"	–
ER 16-DM [mm]					
SET ER 16-DM	1216.00000	3,0–10,0	0,1181–0,3937	–	–
Ø 3,0 mm	1216.03000	3,0 h9	0,1181 h9	–	•
Ø 4,0 mm	1216.04000	4,0 h9	0,1575 h9	–	•
Ø 5,0 mm	1216.05000	5,0–4,5	0,1969–0,1772	–	•
Ø 6,0 mm	1216.06000	6,0–5,5	0,2362–0,2165	–	•
Ø 7,0 mm	1216.07000	7,0–6,5	0,2756–0,2559	–	•
Ø 8,0 mm	1216.08000	8,0–7,5	0,315–0,2953	–	•
Ø 9,0 mm	1216.09000	9,0–8,5	0,3543–0,3346	–	•
Ø 10,0 mm	1216.10000	10,0–9,5	0,3937–0,374	–	•

Expert advice

Please note that the ER-DM collets are not suitable for use with reCool®.

Type	Part no.	Clamping range		Ø [inch]	Included in set
		[mm]	[decimal inch]		
ER 16-DM [inch]					
INCH SET ER 16-DM	1216.00002	3,18 – 10,32	0,125 – 0,4063	–	–
Ø 1/8"	1216.03182	3,18 h9	0,125 h9	1/8"	•
Ø 5/32"	1216.03972	3,97 h9	0,1563 h9	5/32"	–
Ø 3/16"	1216.04762	4,76 h9	0,1875 h9	3/16"	•
Ø 7/32"	1216.05562	5,56 – 5,06	0,2188 – 0,1991	7/32"	–
Ø 1/4"	1216.06352	6,35 – 5,85	0,25 – 0,2303	1/4"	•
Ø 9/32"	1216.07142	7,14 – 6,64	0,2813 – 0,2616	9/32"	–
Ø 5/16"	1216.07942	7,94 – 7,44	0,3125 – 0,2928	5/16"	•
Ø 11/32"	1216.08732	8,73 – 8,23	0,3438 – 0,3241	11/32"	–
Ø 3/8"	1216.09532	9,53 – 9,02	0,375 – 0,3553	3/8"	•
Ø 13/32"	1216.10322	10,32 – 9,82	0,4063 – 0,3866	13/32"	–
ER 20-DM [mm]					
SET ER 20-DM	1220.00000	3,0 – 13,0	0,1181 – 0,5118	–	–
Ø 3,0 mm	1220.03000	3,0 h9	0,1181 h9	–	•
Ø 4,0 mm	1220.04000	4,0 h9	0,1575 h9	–	•
Ø 5,0 mm	1220.05000	5,0 h9	0,1969 h9	–	•
Ø 6,0 mm	1220.06000	6,0 h9	0,2362 h9	–	•
Ø 7,0 mm	1220.07000	7,0 – 6,5	0,2756 – 0,2559	–	•
Ø 8,0 mm	1220.08000	8,0 – 7,5	0,315 – 0,2953	–	•
Ø 9,0 mm	1220.09000	9,0 – 8,5	0,3543 – 0,3346	–	•
Ø 10,0 mm	1220.10000	10,0 – 9,5	0,3937 – 0,374	–	•
Ø 11,0 mm	1220.11000	11,0 – 10,5	0,4331 – 0,4134	–	•
Ø 12,0 mm	1220.12000	12,0 – 11,5	0,4724 – 0,4528	–	•
Ø 13,0 mm	1220.13000	13,0 – 12,5	0,5118 – 0,4921	–	•
ER 20-DM [inch]					
INCH SET ER 20-DM	1220.00002	3,18 – 12,7	0,125 – 0,5	–	–
Ø 1/8"	1220.03182	3,18 h9	0,125 h9	1/8"	•
Ø 5/32"	1220.03972	3,97 h9	0,1563 h9	5/32"	–
Ø 3/16"	1220.04762	4,76 h9	0,1875 h9	3/16"	•
Ø 7/32"	1220.05562	5,56 h9	0,2188 h9	7/32"	–
Ø 1/4"	1220.06352	6,35 h9	0,25 h9	1/4"	•
Ø 9/32"	1220.07142	7,14 – 6,64	0,2813 – 0,2616	9/32"	–
Ø 5/16"	1220.07942	7,94 – 7,44	0,3125 – 0,2928	5/16"	•
Ø 11/32"	1220.08732	8,73 – 8,23	0,3438 – 0,3241	11/32"	–
Ø 3/8"	1220.09532	9,53 – 9,02	0,375 – 0,3553	3/8"	•
Ø 13/32"	1220.10322	10,32 – 9,82	0,4063 – 0,3866	13/32"	–
Ø 7/16"	1220.11112	11,11 – 10,61	0,4375 – 0,4178	7/16"	•
Ø 15/32"	1220.11912	11,91 – 11,41	0,4687 – 0,4491	15/32"	–
Ø 1/2"	1220.12702	12,7 – 12,2	0,5 – 0,4803	1/2"	•

Type	Part no.	Clamping range		Ø [inch]	Included in set
		[mm]	[decimal inch]		
ER 25-DM [mm]					
SET ER 25-DM	1225.00000	6,0–16,0	0,2362–0,6299	–	–
Ø 6,0 mm	1225.06000	6,0 h9	0,2362 h9	–	•
Ø 7,0 mm	1225.07000	7,0 h9	0,2756 h9	–	–
Ø 8,0 mm	1225.08000	8,0–7,5	0,315–0,2953	–	•
Ø 9,0 mm	1225.09000	9,0–8,5	0,3543–0,3347	–	–
Ø 10,0 mm	1225.10000	10,0–9,5	0,3937–0,374	–	•
Ø 11,0 mm	1225.11000	11,0–10,5	0,4331–0,4134	–	–
Ø 12,0 mm	1225.12000	12,0–11,5	0,4724–0,4528	–	•
Ø 13,0 mm	1225.13000	13,0–12,5	0,5118–0,4921	–	–
Ø 14,0 mm	1225.14000	14,0–13,5	0,5512–0,5315	–	•
Ø 15,0 mm	1225.15000	15,0–14,5	0,5906–0,5709	–	–
Ø 16,0 mm	1225.16000	16,0–15,5	0,6299–0,6102	–	•
ER 25-DM [inch]					
INCH SET ER 25-DM	1225.00002	6,35–15,88	0,25–0,625	–	–
Ø 7/32"	1225.05562	5,56 h9	0,2188 h9	7/32"	–
Ø 1/4"	1225.06352	6,35 h9	0,2500 h9	1/4"	•
Ø 9/32"	1225.07142	7,14 h9	0,2813 h9	9/32"	–
Ø 5/16"	1225.07942	7,94–7,44	0,3125–0,2928	5/16"	•
Ø 11/32"	1225.08732	8,73–8,23	0,3438–0,3241	11/32"	–
Ø 3/8"	1225.09532	9,53–9,02	0,375–0,3553	3/8"	•
Ø 13/32"	1225.10322	10,32–9,82	0,4063–0,3866	13/32"	–
Ø 7/16"	1225.11112	11,11–10,61	0,4375–0,4178	7/16"	•
Ø 15/32"	1225.11912	11,91–11,41	0,4687–0,4491	15/32"	–
Ø 1/2"	1225.12702	12,7–12,2	0,5–0,4803	1/2"	•
Ø 17/32"	1225.13492	13,49–12,99	0,5313–0,5116	17/32"	–
Ø 9/16"	1225.14292	14,29–13,79	0,5625–0,5428	9/16"	•
Ø 19/32"	1225.15082	15,08–14,58	0,5934–0,5741	19/32"	–
Ø 5/8"	1225.15882	15,88–15,38	0,625–0,6055	5/8"	•
ER 32-DM [mm]					
SET ER 32-DM	1232.00000	6,0–20,0	0,2362–0,7874	–	–
Ø 6,0 mm	1232.06000	6,0 h9	0,2362 h9	–	•
Ø 7,0 mm	1232.07000	7,0 h9	0,2756 h9	–	–
Ø 8,0 mm	1232.08000	8,0–7,5	0,315–0,2953	–	•
Ø 9,0 mm	1232.09000	9,0–8,5	0,3543–0,3346	–	–
Ø 10,0 mm	1232.10000	10,0–9,5	0,3937–0,374	–	•
Ø 11,0 mm	1232.11000	11,0–10,5	0,4331–0,4134	–	–
Ø 12,0 mm	1232.12000	12,0–11,5	0,4724–0,4528	–	•
Ø 13,0 mm	1232.13000	13,0–12,5	0,5118–0,4921	–	–
Ø 14,0 mm	1232.14000	14,0–13,5	0,5512–0,5315	–	•
Ø 15,0 mm	1232.15000	15,0–14,5	0,5906–0,5709	–	–
Ø 16,0 mm	1232.16000	16,0–15,5	0,6299–0,6102	–	•

Type	Part no.	Clamping range		Ø [inch]	Included in set
		[mm]	[decimal inch]		
Ø 17,0 mm	1232.17000	17,0 – 16,5	0,6693 – 0,6496	–	–
Ø 18,0 mm	1232.18000	18,0 – 17,5	0,7087 – 0,689	–	•
Ø 19,0 mm	1232.19000	19,0 – 18,5	0,748 – 0,7283	–	–
Ø 20,0 mm	1232.20000	20,0 – 19,5	0,7874 – 0,7677	–	•

ER 32-DM [inch]

INCH SET ER 32-DM	1232.00002	6,35 – 19,05	0,25 – 0,75	–	–
Ø 1/4"	1232.06352	6,35 h9	0,25 h9	1/4"	•
Ø 9/32"	1232.07142	7,15 h9	0,2813 h9	9/32"	–
Ø 5/16"	1232.07942	7,94 – 7,44	0,3125 – 0,2928	5/16"	•
Ø 11/32"	1232.08732	8,73 – 8,23	0,3438 – 0,3241	11/32"	–
Ø 3/8"	1232.09532	9,53 – 9,02	0,375 – 0,3553	3/8"	•
Ø 13/32"	1232.10322	10,32 – 9,82	0,4063 – 0,3866	13/32"	–
Ø 7/16"	1232.11112	11,11 – 10,61	0,4375 – 0,4178	7/16"	•
Ø 15/32"	1232.11912	11,91 – 11,41	0,4687 – 0,4491	15/32"	–
Ø 1/2"	1232.12702	12,7 – 12,2	0,5 – 0,4803	1/2"	•
Ø 17/32"	1232.13492	13,5 – 12,99	0,5313 – 0,5116	17/32"	–
Ø 9/16"	1232.14292	14,29 – 13,79	0,5625 – 0,5428	9/16"	•
Ø 19/32"	1232.15082	15,07 – 14,58	0,5934 – 0,5741	19/32"	–
Ø 5/8"	1232.15882	15,88 – 15,38	0,625 – 0,6055	5/8"	•
Ø 21/32"	1232.16672	16,67 – 16,17	0,6563 – 0,6366	21/32"	–
Ø 11/16"	1232.17462	17,46 – 16,96	0,6875 – 0,6678	11/16"	•
Ø 23/32"	1232.18262	18,26 – 17,76	0,7188 – 0,6991	23/32"	–
Ø 3/4"	1232.19052	19,05 – 18,55	0,75 – 0,7303	3/4"	•

ER 40-DM [mm]

Ø 6,0 mm	1240.06000	6,0 h9	0,2362 h9	–	–
Ø 8,0 mm	1240.08000	8,0 h9	0,3150 h9	–	–
Ø 10,0 mm	1240.10000	10,0 – 9,5	0,3937 – 0,374	–	–
Ø 11,0 mm	1240.11000	11,0 – 10,5	0,4331 – 0,4134	–	–
Ø 12,0 mm	1240.12000	12,0 – 11,5	0,4724 – 0,4528	–	–
Ø 13,0 mm	1240.13000	13,0 – 12,5	0,5118 – 0,4921	–	–
Ø 14,0 mm	1240.14000	14,0 – 13,5	0,5512 – 0,5315	–	–
Ø 15,0 mm	1240.15000	15,0 – 14,5	0,5906 – 0,5709	–	–
Ø 16,0 mm	1240.16000	16,0 – 15,5	0,6299 – 0,6102	–	–
Ø 17,0 mm	1240.17000	17,0 – 16,5	0,6693 – 0,6496	–	–
Ø 18,0 mm	1240.18000	18,0 – 17,5	0,7087 – 0,689	–	–
Ø 19,0 mm	1240.19000	19,0 – 18,5	0,748 – 0,7283	–	–
Ø 20,0 mm	1240.20000	20,0 – 19,5	0,7874 – 0,7677	–	–
Ø 21,0 mm	1240.21000	21,0 – 20,5	0,8268 – 0,8071	–	–
Ø 22,0 mm	1240.22000	22,0 – 21,5	0,8661 – 0,8465	–	–
Ø 23,0 mm	1240.23000	23,0 – 22,5	0,9055 – 0,8858	–	–
Ø 24,0 mm	1240.24000	24,0 – 23,5	0,9449 – 0,9252	–	–
Ø 25,0 mm	1240.25000	25,0 – 24,5	0,9843 – 0,9646	–	–
Ø 26,0 mm	1240.26000	26,0 – 25,5	1,0236 – 1,0039	–	–

Type	Part no.	Clamping range		Ø [inch]	Included in set
		[mm]	[decimal inch]		
ER 40-DM [inch]					
Ø 1/4"	1240.06352	6,35 h9	0,25 h9	1/4"	-
Ø 5/16"	1240.07942	7,94 h9	0,3125 h9	5/16"	-
Ø 3/8"	1240.09532	9,53–9,02	0,375–0,3553	3/8"	-
Ø 7/16"	1240.11112	11,11–10,61	0,4375–0,4178	7/16"	-
Ø 1/2"	1240.12702	12,7–12,2	0,5–0,4803	1/2"	-
Ø 9/16"	1240.14292	14,29–13,79	0,5625–0,5428	9/16"	-
Ø 5/8"	1240.15882	15,88–15,38	0,62–0,6055	5/8"	-
Ø 11/16"	1240.17462	17,46–16,96	0,6875–0,6678	11/16"	-
Ø 3/4"	1240.19052	19,05–18,55	0,75–0,7303	3/4"	-
Ø 13/16"	1240.20642	20,64–20,14	0,8123–0,7928	13/16"	-
Ø 7/8"	1240.22232	22,23–21,72	0,875–0,8553	7/8"	-
Ø 1"	1240.25402	25,4–24,9	1,0–0,9803	1"	-

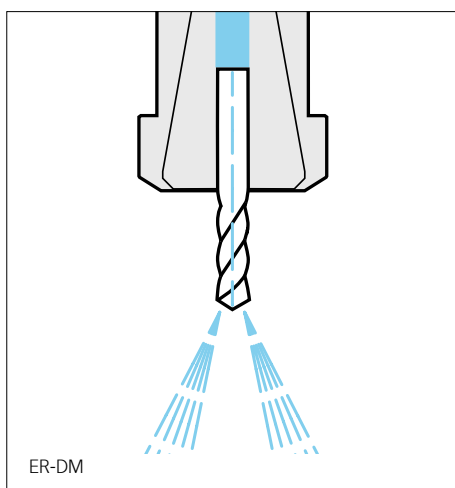

Expert advice

Please note that DM collets are not compatible with Weldon or Whistle notch shafts. To achieve internal cooling with Weldon or Whistle notch shafts, use the REGO-FIX sealing disks ER/DS with your REGO-FIX ER collet.



Hi-Q® | ERMX and Hi-Q® | ERMXC intRlox® Slip-off proof mini clamping nuts

Application For REGO-FIX ER toolholders with mini thread and cylindrical holders.

Key advantages

- // Design is ideally suited for lathes and Swiss turning machines
- // Very slim sizing proofs suitable for machines where space is limited
- // Safe handling thanks to the patented intRlox® profile
- // Slip-off proof design with all advantages of the regular mini clamping nuts
- // Easy and safe clamping with the MX wrench

Application with sealing disk/coolant flush disk The Hi-Q® / ERMXC clamping nut is intended for use with the sealing disk system DS/ER and the coolant flush system KS/ER. The disk system allows the use of all standard ER collets, ultraprecision collets and tapping collets for coolant through tools.

- // Up to 150 bar / 2100 PSI coolant pressure
- // Prevents dirt and chips from entering the collet

For peripheral cooling of non coolant through tools we recommend the coolant flush disks KS/ER. Accessories are not included in delivery.

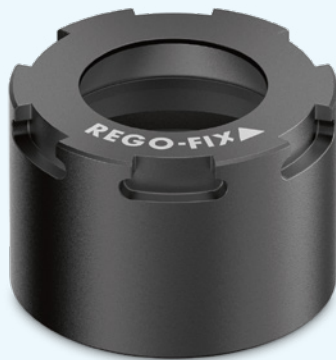

Hi-Q® | ERMX

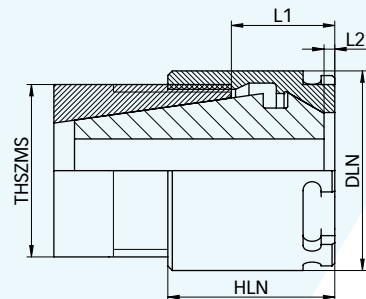

Hi-Q® | ERMX



Hi-Q® | ERMXC

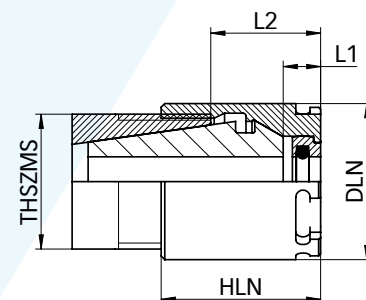

Hi-Q® | ERMXC

Hi-Q® | ERMX intRlox®

Hi-Q® | ERMXC intRlox®

ERMX

ERMXC

Type	Part no.	Dimensions [mm]				THSZMS	Accessories
		DLN	HLN	L1	L2		Wrench
Hi-Q® ERMX 8							
Hi-Q® ERMX 8	3508.60000	12	11	4,3–6,1	0,4	M 10 x 0,75	7118.08000
Hi-Q® ERMX 11							
Hi-Q® ERMX 11	3511.60000	16	12	5,7–7,5	0,4	M 13 x 0,75	7118.11000
Hi-Q® ERMX 16							
Hi-Q® ERMX 16	3516.60000	22	18,4	8,0–11,5	0,9	M 19 x 1	7118.16000
Hi-Q® ERMX 20							
Hi-Q® ERMX 20	3520.60000	28	19	8,0–11,5	0,0	M 24 x 1	7118.20000
Hi-Q® ERMX 25							
Hi-Q® ERMX 25	3525.60000	35	20	8,5–12,0	0,0	M 30 x 1	7118.25000

Type	Part no.	Dimensions [mm]				THSZMS	Accessories
		DLN	HLN	L1	L2		Wrench
Hi-Q® ERMXC 11							
Hi-Q® ERMXC 11	3511.70000	16	14,6	7,5–9,3	3,5	M 13 x 0,75	7118.11000
Hi-Q® ERMXC 16							
Hi-Q® ERMXC 16	3516.70000	22	22,5	11,5–15,0	4,5	M 19 x 1	7118.16000
Hi-Q® ERMXC 20							
Hi-Q® ERMXC 20	3520.70000	28	24	13,0–16,5	5	M 24 x 1	7118.20000
Hi-Q® ERMXC 25							
Hi-Q® ERMXC 25	3525.70000	35	25	13,0–17,0	5	M 30 x 1	7118.25000

Hi-Q® | ERAX with external thread

Hi-Q® | ERAXC for coolant through tools

Application For REGO-FIX floating chucks and other ER toolholders with internal thread, e.g., ERA holders. These nuts can also be used on driven tools with internal threads.

Key advantages

- // Space-saving design for ideal use on long-turning machines
- // intRlox wrench is self-centering on the nut and prevents slipping off while tightening the nut

Application with sealing disk/coolant flush disk The Hi-Q®/ERAXC clamping nut is intended for use with the sealing disk system DS/ER and the coolant flush system KS/ER. The disk system allows the use of all standard ER collets, ultraprecision collets and tapping collets for coolant through tools.

- // Up to 150 bar / 2100 PSI coolant pressure
- // Prevents dirt and chips from entering the collet

For peripheral cooling of non coolant through tools we recommend the coolant flush disks KS/ER.

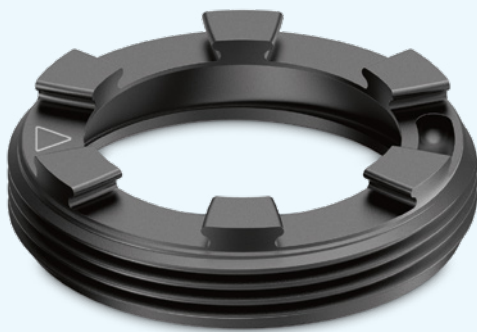

Hi-Q® | ERAX

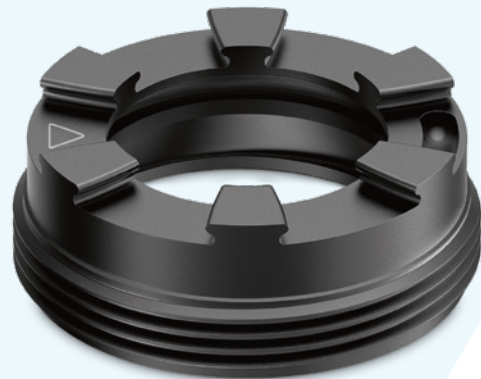

Hi-Q® | ERAXC

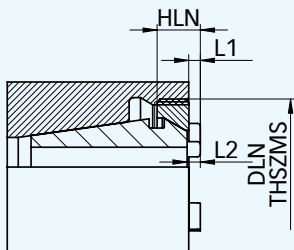

Hi-Q® | ERAX

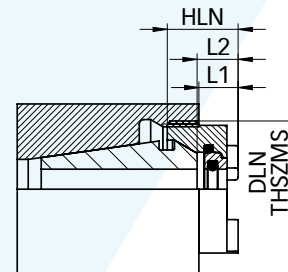

Hi-Q® | ERAXC

Type	Part no.	Dimensions [mm]			THSZMS	Accessories
		HLN	L1	L2		Wrench
Hi-Q® ERAX 11						
Hi-Q® ERAX 11	3311.60000	7,5	1,0–3,2	3,9	M 18 x 1	7117.11000
Hi-Q® ERAX 16						
Hi-Q® ERAX 16	3316.60000	7,6	0–2,6	2,3	M 24 x 1	7117.16000
Hi-Q® ERAX 20						
Hi-Q® ERAX 20	3320.60000	8,5	0–2,5	2,3	M 28 x 1,5	7117.20000
Hi-Q® ERAX 25						
Hi-Q® ERAX 25	3325.60000	8,8	0–1,9	2,3	M 32 x 1,5	7117.25000
Hi-Q® ERAX 32						
Hi-Q® ERAX 32	3332.60000	9,8	0–1,1	2,5	M 40 x 1,5	7117.32000
Hi-Q® ERAX 40						
Hi-Q® ERAX 40	3340.60000	11,7	0–1,0	2,4	M 50 x 1,5	7117.40000

Type	Part no.	Dimensions [mm]			THSZMS	Accessories
		HLN	L1	L2		Wrench
Hi-Q® ERAXC 11						
Hi-Q® ERAXC 11	3311.70000	9,2	2,7–4,9	6,1	M 18 x 1	7117.11000
Hi-Q® ERAXC 16						
Hi-Q® ERAXC 16	3316.70000	12,5	3,1–7,5	7,2	M 24 x 1	7117.16000
Hi-Q® ERAXC 20						
Hi-Q® ERAXC 20	3320.70000	13,5	3,1–7,5	7,3	M 28 x 1,5	7117.20000
Hi-Q® ERAXC 25						
Hi-Q® ERAXC 25	3325.70000	13,8	2,5–6,9	7,3	M 32 x 1,5	7117.25000
Hi-Q® ERAXC 32						
Hi-Q® ERAXC 32	3332.70000	14,9	1,8–6,2	7,6	M 40 x 1,5	7117.32000
Hi-Q® ERAXC 40						
Hi-Q® ERAXC 40	3340.70000	16,6	1,5–5,9	7,3	M 50 x 1,5	7117.40000

Effective solution for internal cooling

Our sealing disks allow you to use your regular collet for internal cooling, saving the need for new collets.

Key advantages

Swiss quality product

Sealing range

0.5 mm

ER 11 has no sealing range and can only be used nominally. Assembling with mounting tool MWZ.

High pressure

For applications up to 150 bar / 2100 PSI.

Protection

Protects against all kind of dirt and chips entering the slots of the collet.

Matched tooling system for best fit

Our long-lasting machining experience results in a well-engineered system. All components are fitted together to one system to maximize your machining potential.

Coolant resistant

O-ring for aggressive coolant (VITON®-quality).

Interchangeable

Quick change of sealing disks according to required tool shank diameter.

Coolant through

For better cooling and lubrication. Extends tool life and supports chip removal.

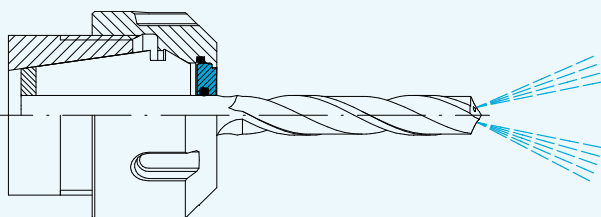
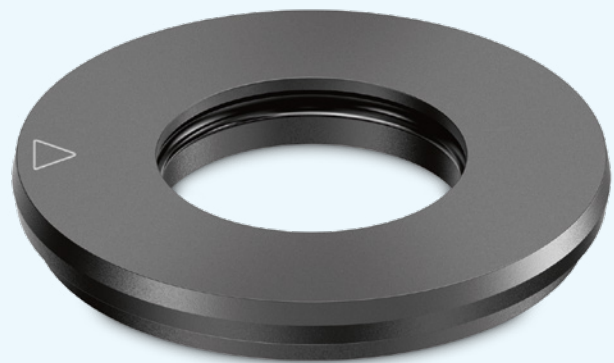

DS/ER

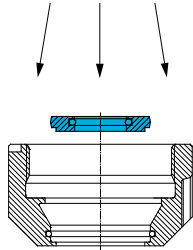

Assembling

Assembling Insert the small diameter of the disk into the center of the coolant nut. Apply an even pressure until the disk is properly seated into the nut.

Removing To remove the disk, simply press on the outside of the disk evenly until it snaps out.

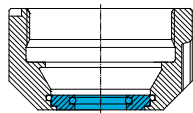

Inserted DS

Expert advice

Insert tool with the shank side first. O-ring might be damaged if cutting tool is inserted from the back with the cutting edge side.

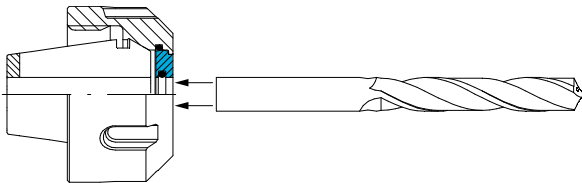

Insert tool

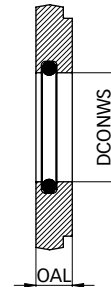

DS/ER

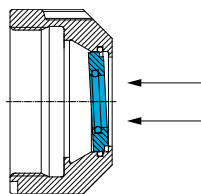

Disk removal

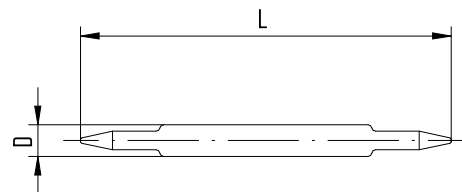

MWZ 11

Type	Part no.	D [mm]	L [mm]	System
MWZ 11 mounting tool for sealing disks				
MWZ 11	3911.88888	12	140	•

Sealing disks for ER/MR

DS / ER

DS / MR

Type	Part no.	Tool diameter			Incl. in set	System
		Ø [inch]	[mm]	[decimal inch]		
DS/ER 11						
Ø 3,0 mm	3911.00300	–	3,0	–	–	•
Ø 1/8"	3911.00318	1/8"	–	–	–	•
Ø 4,0 mm	3911.00400	5/32"	4,0	–	–	•
Ø 3/16"	3911.00476	3/16"	–	–	–	•
Ø 5,0 mm	3911.00500	–	5,0	–	–	•
Ø 6,0 mm	3911.00600	–	6,0	–	–	•
Ø 1/4"	3911.00635	1/4"	–	–	–	•
BLANK DS/ER 11	3911.09999	–	–	–	–	•

ER 11 has no sealing range and can only be used nominally. Assembling with mounting tool MWZ.

DS/ER 16						
SET DS/ER 16 (14 pcs.)	3916.00000	–	3,0–10,0	0,1378–0,3937	–	••
Ø 3,0 mm	3916.00300	3/32"	3,0–2,5	0,1181–0,0984	–	••
Ø 3,5 mm	3916.00350	1/8"	3,5–3,0	0,1378–0,1181	•	••
Ø 4,0 mm	3916.00400	5/32"	4,0–3,5	0,1575–0,1378	•	••
Ø 4,5 mm	3916.00450	–	4,5–4,0	0,1772–0,1575	•	••
Ø 5,0 mm	3916.00500	3/16"	5,0–4,5	0,1969–0,1772	•	••
Ø 5,5 mm	3916.00550	7/32"	5,5–5,0	0,2165–0,1969	•	••
Ø 6,0 mm	3916.00600	–	6,0–5,5	0,2362–0,2165	•	••
Ø 6,5 mm	3916.00650	1/4"	6,5–6,0	0,2559–0,2362	•	••
Ø 7,0 mm	3916.00700	–	7,0–6,5	0,2756–0,2559	•	••
Ø 7,5 mm	3916.00750	9/32"	7,5–7,0	0,2953–0,2756	•	••
Ø 8,0 mm	3916.00800	5/16"	8,0–7,5	0,315–0,2953	•	••
Ø 8,5 mm	3916.00850	–	8,5–8,0	0,3346–0,315	•	••
Ø 9,0 mm	3916.00900	11/32"	9,0–8,5	0,3543–0,3346	•	••
Ø 9,5 mm	3916.00950	3/8"	9,5–9,0	0,374–0,3543	•	••
Ø 10,0 mm	3916.01000	–	10,0–9,5	0,3937–0,374	•	••
BLANK DS/ER 16	3916.09999	–	–	–	–	••

Included in the DS/ER sets are all marked disks within that ER size and the matching disk try DSR

DS/ER 20						
SET DS/ER 20 (20 pcs.)	3920.00000	–	3,0–13,0	0,1378–0,5118	–	•
Ø 3,0 mm	3920.00300	3/32"	3,0–2,5	0,1181–0,0984	–	•
Ø 3,5 mm	3920.00350	1/8"	3,5–3,0	0,1378–0,1181	•	•
Ø 4,0 mm	3920.00400	5/32"	4,0–3,5	0,1575–0,1378	•	•
Ø 4,5 mm	3920.00450	–	4,5–4,0	0,2165–0,1969	•	•
Ø 5,0 mm	3920.00500	3/16"	5,0–4,5	0,1969–0,1772	•	•
Ø 5,5 mm	3920.00550	7/32"	5,5–5,0	0,1772–0,1575	•	•
Ø 6,0 mm	3920.00600	–	6,0–5,5	0,2362–0,2165	•	•
Ø 6,5 mm	3920.00650	1/4"	6,5–6,0	0,2559–0,2362	•	•
Ø 7,0 mm	3920.00700	–	7,0–6,5	0,2756–0,2559	•	•
Ø 7,5 mm	3920.00750	9/32"	7,5–7,0	0,2953–0,2756	•	•
Ø 8,0 mm	3920.00800	5/16"	8,0–7,5	0,315–0,2953	•	•
Ø 8,5 mm	3920.00850	–	8,5–8,0	0,3346–0,315	•	•

Sealing disks for ER/MR

DS / ER

DS / MR

Type	Part no.	Tool diameter			Incl. in set	System
		Ø [inch]	[mm]	[decimal inch]		
Ø 9,0 mm	3920.00900	11/32"	9,0–8,5	0,3543–0,3346	•	•
Ø 9,5 mm	3920.00950	3/8"	9,5–9,0	0,374–0,3543	•	•
Ø 10,0 mm	3920.01000	–	10,0–9,5	0,3937–0,374	•	•
Ø 10,5 mm	3920.01050	13/32"	10,5–10,0	0,4134–0,3937	•	•
Ø 11,0 mm	3920.01100	–	11,0–10,5	0,433–0,4134	•	•
Ø 11,5 mm	3920.01150	7/16"	11,5–11,0	0,4528–0,4331	•	•
Ø 12,0 mm	3920.01200	15/32"	12,0–11,5	0,4724–0,4528	•	•
Ø 12,5 mm	3920.01250	–	12,5–12,0	0,4921–0,4724	•	•
Ø 13,0 mm	3920.01300	1/2"	13,0–12,5	0,5118–0,4921	•	•
BLANK DS/ER 20	3920.09999	–	–	–	–	•

Included in the DS/ER sets are all marked disks within that ER size and the matching disk try DSR

DS/ER 25

SET DS/ER 25 (26 pcs.)	3925.00000	–	3,0–16,0	0,1181–0,6299	–	••
Ø 3,0 mm	3925.00300	3/32"	3,0–2,5	0,1181–0,0984	–	••
Ø 3,5 mm	3925.00350	1/8"	3,5–3,0	0,1378–0,1181	•	••
Ø 4,0 mm	3925.00400	5/32"	4,0–3,5	0,1575–0,1378	•	••
Ø 4,5 mm	3925.00450	–	4,5–4,0	0,1772–0,1575	•	••
Ø 5,0 mm	3925.00500	3/16"	5,0–4,5	0,1969–0,1772	•	••
Ø 5,5 mm	3925.00550	7/32"	5,5–5,0	0,2165–0,1969	•	••
Ø 6,0 mm	3925.00600	–	6,0–5,5	0,2362–0,2165	•	••
Ø 6,5 mm	3925.00650	1/4"	6,5–6,0	0,2559–0,2362	•	••
Ø 7,0 mm	3925.00700	–	7,0–6,5	0,2756–0,2559	•	••
Ø 7,5 mm	3925.00750	9/32"	7,5–7,0	0,2953–0,2756	•	••
Ø 8,0 mm	3925.00800	5/16"	8,0–7,5	0,315–0,2953	•	••
Ø 8,5 mm	3925.00850	–	8,5–8,0	0,3346–0,315	•	••
Ø 9,0 mm	3925.00900	11/32"	9,0–8,5	0,3543–0,3347	•	••
Ø 9,5 mm	3925.00950	3/8"	9,5–9,0	0,374–0,3543	•	••
Ø 10,0 mm	3925.01000	–	10,0–9,5	0,3937–0,374	•	••
Ø 10,5 mm	3925.01050	13/32"	10,5–10,0	0,4134–0,3937	•	••
Ø 11,0 mm	3925.01100	–	11,0–10,5	0,433–0,4134	•	••
Ø 11,5 mm	3925.01150	7/16"	11,5–11,0	0,4528–0,433	•	••
Ø 12,0 mm	3925.01200	15/32"	12,0–11,5	0,4724–0,4528	•	••
Ø 12,5 mm	3925.01250	–	12,5–12,0	0,4921–0,4724	•	••
Ø 13,0 mm	3925.01300	1/2"	13,0–12,5	0,2118–0,4921	•	••
Ø 13,5 mm	3925.01350	17/32"	13,5–13,0	0,5315–0,5118	•	••
Ø 14,0 mm	3925.01400	–	14,0–13,5	0,5512–0,5315	•	••
Ø 14,5 mm	3925.01450	9/16"	14,5–14,0	0,5709–0,5512	•	••
Ø 15,0 mm	3925.01500	–	15,0–14,5	0,5906–0,5709	•	••
Ø 15,5 mm	3925.01550	19/32"	15,5–15,0	0,6102–0,5906	•	••
Ø 16,0 mm	3925.01600	5/8"	16,0–15,5	0,6299–0,6102	•	••
BLANK DS/ER 25	3925.09999	–	–	–	–	••

Included in the DS/ER sets are all marked disks within that ER size and the matching disk try DSR

Sealing disks for ER/MR

DS / ER

DS / MR

Type	Part no.	Tool diameter			Incl. in set	System
		Ø [inch]	[mm]	[decimal inch]		
DS/ER 32						
DS/ER 32 SET (34 pcs.)	3932.00000	–	3,0–20,0	0,1181–0,7874	–	••
Ø 3,0 mm	3932.00300	3/32"	3,0–2,5	0,1181–0,0984	–	••
Ø 3,5 mm	3932.00350	1/8"	3,5–3,0	0,1378–0,1181	•	••
Ø 4,0 mm	3932.00400	5/32"	4,0–3,5	0,1575–0,1378	•	••
Ø 4,5 mm	3932.00450	–	4,5–4,0	0,1772–0,1575	•	••
Ø 5,0 mm	3932.00500	3/16"	5,0–4,5	0,1969–0,1772	•	••
Ø 5,5 mm	3932.00550	7/32"	5,5–5,0	0,2165–0,1969	•	••
Ø 6,0 mm	3932.00600	–	6,0–5,5	0,2362–0,2165	•	••
Ø 6,5 mm	3932.00650	1/4"	6,5–6,0	0,2559–0,2362	•	••
Ø 7,0 mm	3932.00700	–	7,0–6,5	0,2756–0,2559	•	••
Ø 7,5 mm	3932.00750	9/32"	7,5–7,0	0,2953–0,2756	•	••
Ø 8,0 mm	3932.00800	5/16"	8,0–7,5	0,315–0,2953	•	••
Ø 8,5 mm	3932.00850	–	8,5–8,0	0,3346–0,315	•	••
Ø 9,0 mm	3932.00900	11/32"	9,0–8,5	0,3543–0,3346	•	••
Ø 9,5 mm	3932.00950	3/8"	9,5–9,0	0,374–0,3543	•	••
Ø 10,0 mm	3932.01000	–	10,0–9,5	0,3937–0,374	•	••
Ø 10,5 mm	3932.01050	13/32"	10,5–10,0	0,4134–0,3937	•	••
Ø 11,0 mm	3932.01100	–	11,0–10,5	0,4331–0,4134	•	••
Ø 11,5 mm	3932.01150	7/16"	11,5–11,0	0,4528–0,4331	•	••
Ø 12,0 mm	3932.01200	15/32"	12,0–11,5	0,4724–0,4528	•	••
Ø 12,5 mm	3932.01250	–	12,5–12,0	0,4921–0,4724	•	••
Ø 13,0 mm	3932.01300	1/2"	13,0–12,5	0,5118–0,4921	•	••
Ø 13,5 mm	3932.01350	17/32"	13,5–13,0	0,5315–0,5118	•	••
Ø 14,0 mm	3932.01400	–	14,0–13,5	0,5512–0,5315	•	••
Ø 14,5 mm	3932.01450	9/16"	14,5–14,0	0,5709–0,5512	•	••
Ø 15,0 mm	3932.01500	–	15,0–14,5	0,5905–0,5709	•	••
Ø 15,5 mm	3932.01550	19/32"	15,5–15,0	0,6102–0,5906	•	••
Ø 16,0 mm	3932.01600	5/8"	16,0–15,5	0,6299–0,6102	•	••
Ø 16,5 mm	3932.01650	–	16,5–16,0	0,6496–0,6299	•	••
Ø 17,0 mm	3932.01700	21/32"	17,0–16,5	0,6693–0,6496	•	••
Ø 17,5 mm	3932.01750	11/16"	17,5–17,0	0,689–0,6693	•	••
Ø 18,0 mm	3932.01800	–	18,0–17,5	0,7087–0,689	•	••
Ø 18,5 mm	3932.01850	23/32"	18,5–18,0	0,7283–0,7087	•	••
Ø 19,0 mm	3932.01900	3/4"	19,0–18,5	0,748–0,7283	•	••
Ø 19,5 mm	3932.01950	–	19,5–19,0	0,7677–0,748	•	••
Ø 20,0 mm	3932.02000	25/32"	20,0–19,5	0,7874–0,7677	•	••
BLANK DS/ER 32	3932.09999	–	–	–	–	••

Included in the DS/ER sets are all marked disks within that ER size and the matching disk try DSR

Type	Part no.	Tool diameter			Incl. in set	System
		Ø [inch]	[mm]	[decimal inch]		
DS/ER 40						
DS/ER 40 SET (46 pcs.)	3940.00000	–	3,0–26,0	0,1181–1,0236	–	•
Ø 3,0 mm	3940.00300	3/32"	3,0–2,5	0,1181–0,0984	–	•
Ø 3,5 mm	3940.00350	1/8"	3,5–3,0	0,1378–0,1181	•	•
Ø 4,0 mm	3940.00400	5/32"	4,0–3,5	0,1575–0,1378	•	•
Ø 4,5 mm	3940.00450	–	4,5–4,0	0,1772–0,1575	•	•
Ø 5,0 mm	3940.00500	3/16"	5,0–4,5	0,1969–0,1772	•	•
Ø 5,5 mm	3940.00550	7/32"	5,5–5,0	0,2165–0,1969	•	•
Ø 6,0 mm	3940.00600	–	6,0–5,5	0,2362–0,2165	•	•
Ø 6,5 mm	3940.00650	1/4"	6,5–6,0	0,2559–0,2362	•	•
Ø 7,0 mm	3940.00700	–	7,0–6,5	0,2756–0,2559	•	•
Ø 7,5 mm	3940.00750	9/32"	7,5–7,0	0,2953–0,2756	•	•
Ø 8,0 mm	3940.00800	5/16"	8,0–7,5	0,315–0,2953	•	•
Ø 8,5 mm	3940.00850	–	8,5–8,0	0,3347–0,315	•	•
Ø 9,0 mm	3940.00900	11/32"	9,0–8,5	0,3543–0,3347	•	•
Ø 9,5 mm	3940.00950	3/8"	9,5–9,0	0,374–0,3543	•	•
Ø 10,0 mm	3940.01000	–	10,0–9,5	0,3937–0,374	•	•
Ø 10,5 mm	3940.01050	13/32"	10,5–10,0	0,4134–0,3937	•	•
Ø 11,0 mm	3940.01100	–	11,0–10,5	0,433–0,4134	•	•
Ø 11,5 mm	3940.01150	7/16"	11,5–11,0	0,4528–0,433	•	•
Ø 12,0 mm	3940.01200	15/32"	12,0–11,5	0,4724–0,4528	•	•
Ø 12,5 mm	3940.01250	–	12,5–12,0	0,4921–0,4724	•	•
Ø 13,0 mm	3940.01300	1/2"	13,0–12,5	0,5118–0,4921	•	•
Ø 13,5 mm	3940.01350	17/32"	13,5–13,0	0,5315–0,5118	•	•
Ø 14,0 mm	3940.01400	–	14,0–13,5	0,5512–0,5315	•	•
Ø 14,5 mm	3940.01450	9/16"	14,5–14,0	0,5709–0,5512	•	•
Ø 15,0 mm	3940.01500	–	15,0–14,5	0,5905–0,5709	•	•
Ø 15,5 mm	3940.01550	19/32"	15,5–15,0	0,6102–0,5905	•	•
Ø 16,0 mm	3940.01600	5/8"	16,0–15,5	0,6299–0,6102	•	•
Ø 16,5 mm	3940.01650	–	16,5–16,0	0,6496–0,6299	•	•
Ø 17,0 mm	3940.01700	21/32"	17,0–16,5	0,6693–0,6496	•	•
Ø 17,5 mm	3940.01750	11/16"	17,5–17,0	0,689–0,6693	•	•
Ø 18,0 mm	3940.01800	–	18,0–17,5	0,7087–0,689	•	•
Ø 18,5 mm	3940.01850	23/32"	18,5–18,0	0,7283–0,7087	•	•
Ø 19,0 mm	3940.01900	3/4"	19,0–18,5	0,748–0,7283	•	•
Ø 19,5 mm	3940.01950	–	19,5–19,0	0,7677–0,748	•	•
Ø 20,0 mm	3940.02000	23/32"	20,0–19,5	0,7874–0,7677	•	•
Ø 20,5 mm	3940.02050	–	20,5–20,0	0,8071–0,7874	•	•
Ø 21,0 mm	3940.02100	13/16"	21,0–20,5	0,8268–0,8071	•	•
Ø 21,5 mm	3940.02150	25/32"	21,5–21,0	0,8465–0,8268	•	•

Type	Part no.	Tool diameter			Incl. in set	System
		Ø [inch]	[mm]	[decimal inch]		
Ø 22,0 mm	3940.02200	-	22,0–21,5	0,8661–0,8465	•	•
Ø 22,5 mm	3940.02250	7/8"	22,5–22,0	0,8858–0,8268	•	•
Ø 23,0 mm	3940.02300	29/32"	23,0–22,5	0,9055–0,8858	•	•
Ø 23,5 mm	3940.02350	-	23,5–23,0	0,9252–0,9055	•	•
Ø 24,0 mm	3940.02400	15/16"	24,0–23,5	0,9449–0,9252	•	•
Ø 24,5 mm	3940.02450	-	24,5–24,0	0,9646–0,9449	•	•
Ø 25,0 mm	3940.02500	31/32"	25,0–24,5	0,9843–0,9646	•	•
Ø 25,5 mm	3940.02550	1"	25,5–25,0	1,0039–0,9843	•	•
Ø 26,0 mm	3940.02600	-	26,0–25,5	1,0236–1,0039	•	•
BLANK DS/ER 40	3940.09999	-	-	-	-	•

Included in the DS/ER sets are all marked disks within that ER size and the matching disk try DSR

DS/ER 50

ADP ERC 50 / DS KS 40*	3950.40000	-	3,0–26,0	0,1181–1,0236	-	•
Ø 22,0 mm	3950.02200	-	22,0–21,5	0,8661–0,8465	-	•
Ø 25,0 mm	3950.02500	-	25,0–24,5	0,9842–0,9645	-	•
Ø 28,0 mm	3950.02800	-	28,0–27,5	1,1023–1,0827	-	•
Ø 32,0 mm	3950.03200	-	32,0–31,5	1,2598–1,2402	-	•
Ø 36,0 mm	3950.03600	-	36,0–35,5	1,4173–1,3976	-	•

*The ADP ER 50-DS/ER 40 only works in combination with a sealing disk DS/ER 40. DS/ER 40 is not included in delivery

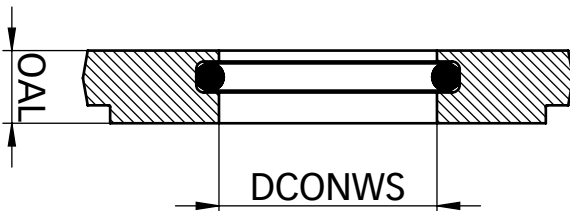

DS / ER

Expert advice

The BLANK DS/ER is used as machining blank for specific sizes or as sealing disk for double-sided driven tools.

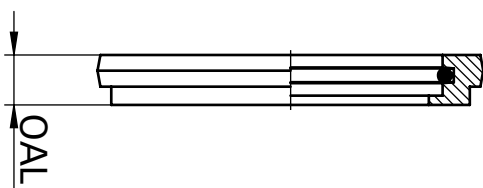

ADP ERC / DS | KS

Expert advice

The adapter ADP ER 50–DS/ER 40 allows the use of DS/ER-40 sealing disks in ER-50 clamping nuts.

Our solution for peripheral cooling

The design of our coolant flush disks leads the coolant along the edge of the cutting tool, providing you with an easy way to achieve peripheral cooling.

Key advantages

Swiss quality product

Universal use

For all REGO-FIX collets and coolant nuts with interchangeable disk.

Interchangeable

Quick change of coolant flush disks according to required tool shank diameter.

Peripheral cooling

For better cooling and lubrication.
Extends tool life and supports chip removal.

Original REGO-FIX

Our long-lasting machining experience results in a well-engineered system. When buying ER coolant flush disks please pay attention to the REGO-FIX quality seal on the coolant flush disk: The triangle is our seal for outstanding quality made in Switzerland.

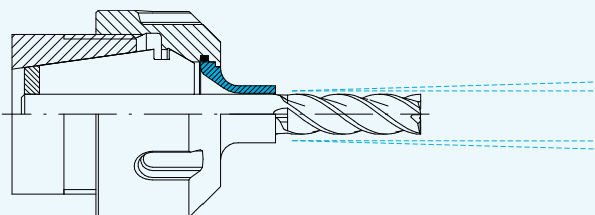

KS/ER

Coolant flush disks for ER/MR

KS / ER

KS / MR

Type	Part no.	Dimensions [mm]		Ø		System
		D	L	[mm]	[inch]	
KS/ER 11 [mm]/[inch]						
Ø 3,0 mm / 1/8"	3911.30318	5,6	5,5	3	1/8"	•
Ø 4,0 mm	3911.20400	6,4	5,5	4	–	•
Ø 5,0 mm / 3/16"	3911.20500	7,5	5,5	5	3/16"	•
Ø 6,0 mm / 1/4"	3911.30635	7,5	5,5	6	1/4"	•
BLANK KS / ER 11*	3911.29999	7,5	8	–	–	•

KS/ER 16 [mm]						
Ø 3,0 mm	3916.20300	6,4	11	3	–	••
Ø 4,0 mm	3916.20400	7,4	11	4	–	••
Ø 5,0 mm	3916.20500	8,4	11	5	–	••
Ø 6,0 mm	3916.20600	9,4	11	6	–	••
Ø 7,0 mm	3916.20700	11	11	7	–	••
Ø 8,0 mm	3916.20800	11	11	8	–	••
Ø 9,0 mm	3916.20900	11	2	9	–	••
Ø 10,0 mm	3916.21000	11	2	10	–	••
BLANK KS / ER 16*	3916.29999	11	12	–	–	••

KS/ER 16 [inch]						
Ø 1/8"	3916.30318	6,6	11	3,175	1/8"	••
Ø 3/16"	3916.30476	8,2	11	4,763	3/16"	••
Ø 1/4"	3916.30635	9,7	11	6,35	1/4"	••
Ø 5/16"	3916.30794	11	11	7,938	5/16"	••
Ø 3/8"	3916.30953	11	2	9,525	3/8"	••

KS/ER 20 [mm]						
Ø 3,0 mm	3920.20300	6,4	11	3	–	•
Ø 4,0 mm	3920.20400	7,4	11	4	–	•
Ø 5,0 mm	3920.20500	8,4	11	5	–	•
Ø 6,0 mm	3920.20600	9,4	11	6	–	•
Ø 7,0 mm	3920.20700	10,4	11	7	–	•
Ø 8,0 mm	3920.20800	11,4	11	8	–	•
Ø 9,0 mm	3920.20900	12,4	11	9	–	•
Ø 10,0 mm	3920.21000	14	11	10	–	•
Ø 12,0 mm	3920.21200	14	3	12	–	•
BLANK KS / ER 20*	3920.29999	14	12	–	–	•

*Work material: 42CrMoS4 (1.7227)

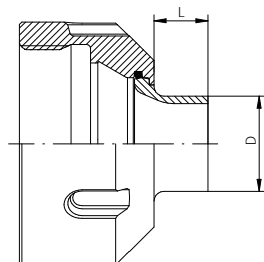

KS/ER

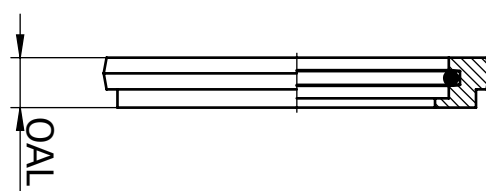

ADP ERC / DS | KS

Coolant flush disks for ER / MR

KS / ER

KS / MR

Type	Part no.	Dimensions [mm]		Ø		System
		D	L	[mm]	[inch]	
KS/ER 20 [inch]						
Ø 1/8"	3920.30318	6,6	11	3,175	1/8"	•
Ø 3/16"	3920.30476	8,2	11	4,763	3/16"	•
Ø 1/4"	3920.30635	9,7	11	6,35	1/4"	•
Ø 5/16"	3920.30794	11,3	11	7,983	5/16"	•
Ø 3/8"	3920.30953	14	11	9,525	3/8"	•
Ø 7/16"	3920.31111	14	11	11,113	7/16"	•
Ø 1/2"	3920.31270	14	3	12,7	1/2"	•

KS/ER 25 [mm]						
Ø 3,0 mm	3925.20300	6,4	11	3	–	••
Ø 4,0 mm	3925.20400	7,4	11	4	–	••
Ø 5,0 mm	3925.20500	8,4	11	5	–	••
Ø 6,0 mm	3925.20600	9,4	11	6	–	••
Ø 7,0 mm	3925.20700	10,4	11	7	–	••
Ø 8,0 mm	3925.20800	11,4	11	8	–	••
Ø 9,0 mm	3925.20900	12,4	11	9	–	••
Ø 10,0 mm	3925.21000	13,4	11	10	–	••
Ø 12,0 mm	3925.21200	15,4	11	12	–	••
Ø 14,0 mm	3925.21400	17,4	11	14	–	••
Ø 16,0 mm	3925.21600	19	11	16	–	••
BLANK KS / ER 25*	3925.29999	19	12	–	–	••

KS/ER 25 [inch]						
Ø 1/8"	3925.30318	6,6	11	3,175	1/8"	••
Ø 3/16"	3925.30476	8,2	11	4,763	3/16"	••
Ø 1/4"	3925.30635	9,7	11	6,35	1/4"	••
Ø 5/16"	3925.30794	11,3	11	7,938	5/16"	••
Ø 3/8"	3925.30953	12,9	11	9,525	3/8"	••
Ø 7/16"	3925.31111	14,5	11	11,113	7/16"	••
Ø 1/2"	3925.31270	16,1	11	12,7	1/2"	••
Ø 9/16"	3925.31429	17,7	11	14,288	9/16"	••
Ø 5/8"	3925.31588	19	11	15,875	5/8"	••

*Work material: 42CrMoS4 (1.7227)

Coolant flush disks for ER/MR

KS / ER

KS / MR

Type	Part no.	Dimensions [mm]		Ø		System
		D	L	[mm]	[inch]	
KS / ER 32 [mm]						
Ø 3,0 mm	3932.20300	6,4	11	3	–	••
Ø 4,0 mm	3932.20400	7,4	11	4	–	••
Ø 5,0 mm	3932.20500	8,4	11	5	–	••
Ø 6,0 mm	3932.20600	9,4	11	6	–	••
Ø 7,0 mm	3932.20700	10,4	11	7	–	••
Ø 8,0 mm	3932.20800	11,4	11	8	–	••
Ø 9,0 mm	3932.20900	12,4	11	9	–	••
Ø 10,0 mm	3932.21000	13,4	11	10	–	••
Ø 12,0 mm	3932.21200	15,4	11	12	–	••
Ø 14,0 mm	3932.21400	17,4	11	14	–	••
Ø 16,0 mm	3932.21600	19,4	11	16	–	••
Ø 18,0 mm	3932.21800	21,4	11	18	–	••
Ø 20,0 mm	3932.22000	24	11	20	–	••
BLANK KS / ER 32*	3932.29999	24	12	–	–	••

KS / ER 32 [inch]						
Ø 1/8"	3932.30318	6,6	11	3,175	1/8"	••
Ø 3/16"	3932.30476	8,2	11	4,763	3/16"	••
Ø 1/4"	3932.30635	9,7	11	6,35	1/4"	••
Ø 5/16"	3932.30794	11,3	11	7,938	5/16"	••
Ø 3/8"	3932.30953	12,9	11	9,525	3/8"	••
Ø 7/16"	3932.31111	14,5	11	11,113	7/16"	••
Ø 1/2"	3932.31270	16,1	11	12,7	1/2"	••
Ø 9/16"	3932.31429	17,7	11	14,288	9/16"	••
Ø 5/8"	3932.31588	19,3	11	15,875	5/8"	••
Ø 3/4"	3932.31905	24	11	19,05	3/4"	••

*Work material: 42CrMoS4 (1.7227).

KS / ER 40						
ADP ERC 40 / DS KS 32	3940.32000	–	–	3-20	1/8" - 3/4"	•

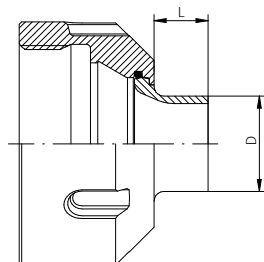

KS/ER

Maintenance instructions for floating chucks

Anwendung des Pendelhalters

Standing application

Rotating application

Adjustment of the self-centering force

For heavy tools, turn adjusting screw clockwise. For light tools, turn adjusting screw further to free floating.

Select stronger self-centering to avoid premature deflection by centrifugal forces.

Maintenance interval

Holder in use

Holder not in use, but is located in tool changer of the machine.

Holder not in use for a long time

Maintenance intervals depend on climatic and environmental conditions

Lubrication

every 2 working weeks

every 2 working weeks

before storage

! Do not turn the adjusting screw all the way when floating function is required, always turn the adjusting screw one turn away from the

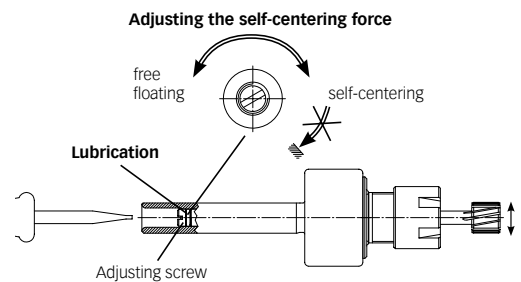

There are two main versions of floating chucks

MPHC



With 2 screws on the side of the flange.

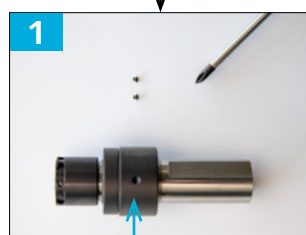

Take both screws out with a fitting screwdriver (PH0). Blow out with dry pressurized air.



Put one screw back. Fill with 10 drops of thin oil.



Put the second screw back.

MPH



With one screw in the cylindrical shaft on the back of the floating chuck.



Take the screw in the cylinder out with a fitting screwdriver (hex screw). Blow out with dry pressurized air. Fill with 10 drops of thin oil.

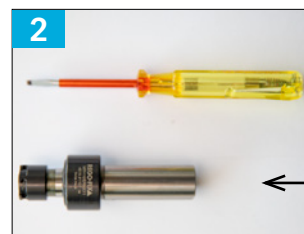

Put the screw back in the back (do not forget the spring). Re-adjust the spring tension in the cylinder shaft.

