

PGS 25/15/10 (E/J/A)

REGO-FIX▲





## Operating manual

PGS 25/15/10 (E/J/A)

# Foreword

This document represents the operating instructions for the PGS 25/15/10 (E/J/A) clamping unit and contains important specifications and information to enable safe, proper and economical machine operation.

All specifications assume that the clamping unit is used as described in section ► 2.2 [□ 7].

All illustrations in this document serve to support the explanations presented in text form and are not necessarily to scale. Depending on the product variant, the images and illustrations shown may differ slightly from the clamping unit included in the scope of delivery.

The operating instructions are part of the clamping unit



- // For safe operation and the fulfilment of any warranty claims, first read the operating instructions and follow the instructions.
- // Pass on the operating instructions to the next owner.
- // No liability is accepted for damage and malfunctions resulting from non-observance of the operating instructions.
- // Contact the manufacturer's customer service (info@rego-fix.com) if you have any questions about the operating manual.

## Copyright protection

The copyright of this document belongs to REGO-FIX AG (manufacturer).

The operating instructions are to be treated as a confidential document and are intended exclusively for persons working with the clamping unit. The operating instructions may not be made available to third parties without the written consent of the manufacturer. The content of the operating instructions in the form of text, images, illustrations, drawings, diagrams or other representations is protected by copyright by the manufacturer and is subject to industrial property rights. Any misuse is punishable by law.

Reproduction of this document (also in part) as well as commercial exploitation is expressly prohibited and only permitted with a written declaration by the manufacturer in exceptional cases.

**Name:** PGS 25/15/10 (E/J/A)

**Manufacturer:** REGO-FIX AG, Obermattweg 60, CH-4456 Tenniken, Switzerland  
Phone +41 61 976 14 66, info@rego-fix.com

**Technical changes:** The manufacturer reserves the right to make changes in the sense of technical improvements.

**Document number:** 600011309

This instruction manual must be kept for as long as the device is in use.



# Table of contents

|   |           |   |           |
|---|-----------|---|-----------|
| <b>1. General information</b>                       | <b>6</b>  | <b>4. Operating modes</b>                     | <b>23</b> |
| 1.1 Storage   | 6         | 4.1 Transport                                 | 23        |
| 1.2 Limitation of liability                         | 6         | 4.2 Start-up                                  | 27        |
| 1.3 Customer support                                | 6         | 4.3 Normal operation                          | 31        |
| <b>2. Security</b>                                  | <b>7</b>  | 4.4 Troubleshooting and problem solving       | 36        |
| 2.1 Basic safety information                        | 7         | 4.5 Servicing and maintenance                 | 42        |
| 2.2 Intended use                                    | 7         | 4.6 Disassembly and disposal                  | 43        |
| 2.3 Requirements for the machine operator           | 8         | <b>5. powRgrip® cleaning instructions</b>     | <b>44</b> |
| 2.4 Identification of residual hazards              | 10        | <b>6. Technical data powRgrip®</b>            | <b>45</b> |
| 2.5 Presentation forms – warnings                   | 10        | <b>7. Spare parts</b>                         | <b>46</b> |
| 2.6 Residual risks of the different operating modes | 12        | <b>8. Drawings and diagrams</b>               | <b>47</b> |
| <b>3. Device description</b>                        | <b>16</b> | 8.1 Hydraulic diagram                         | 48        |
| 3.1 Overall view of the clamping unit               | 16        | 8.2 Electrical diagram                        | 49        |
| 3.2 Overall view of the pressing head               | 17        | <b>9. EC Declaration of Conformity</b>        | <b>52</b> |
| 3.3 How the powRgrip® system works                  | 18        | <b>10. Technical data sheet hydraulic oil</b> | <b>53</b> |
| 3.4 Functionality of the clamping unit PGS 25/15/10 | 18        |   |           |
| 3.5 Labelling                                       | 19        |   |           |
| 3.6 Specifications                                  | 20        |   |           |
| 3.7 Delivered condition and packaging               | 22        |   |           |

# 1. General information

## 1.1 Storage

- // The operating instructions must be stored in the immediate proximity of the clamping unit and protected from immissions.
- // Workplace staff must have access to the operating manual at all times.
- // The contents of the operating instructions must be clearly legible throughout the service life of the device. If parts of the operating manual are missing or no longer legible, the manufacturer must be contacted so that the documentation can be restored.

## 1.2 Limitation of liability

The content of this manual was compiled in compliance with applicable guidelines and standards and on the basis of the latest technology standards and our many years of experience. The manufacturer does not accept liability for any damages or accidents resulting from:

- // Disregard of instructions
- // Non-compliance with safety regulations
- // Improper use of the machine
- // Disregard of personnel qualifications
- // Any modifications to the machine or (sub-)components installed therein that have not been agreed with the manufacturer and are expressly permitted

The requirements set out in the supply or purchase agreement, the general terms and conditions, the manufacturer's delivery terms and the international and national regulations in place when the agreement was concluded also apply.

## 1.3 Customer support

Direct support is available from your local sales representative.

For technical queries, please contact our support team at [info@rego-fix.com](mailto:info@rego-fix.com).

You can find information about the relevant contact persons at any time either via the contact address above or via our website ([rego-fix.com](http://rego-fix.com)).

## 2. Security

### 2.1 Basic safety information

The security officer must ensure that

- // only qualified personnel are assigned to work on the clamping unit. Specifications for the work to be carried out depending on the selected operating mode are summarised in section ► 2.3 [□ 8].
- // the necessary personnel training is carried out.
- // the operating personnel have the operating instructions and other safety-relevant documents in the product documentation available at all times for all work and are obliged to strictly observe these documents.
- // staff observe the accident prevention rules and regulations in force at the location as well as maintenance and calibration cycles.
- // the applicable safety and environmental protection regulations are complied with.
- // hazards resulting from the installation location and/or type of installation of the machine as well as the operating ambient conditions are evaluated and documented and taken into account in the form of instructions.

The clamping unit may only be used within the scope of its intended use (see section ► 2.2 [□ 7]). Furthermore, the clamping unit may only be used in a technically flawless and operationally reliable condition. Before commissioning and after maintenance or repair work has been carried out, the clamping unit must be checked to ensure that it is intact.

### 2.2 Intended use

- // **This clamping unit is a hydraulic assembly press for semi-automated pressing in and out of cutting tools with shank using powRgrip® technology from REGO-FIX AG.**
- // **For the intended use of the clamping unit and the safe operation enabled as a result, the following conditions must also be met:**
  - / The clamping unit may be used only for the modes of operation specified in section ► 4 [□ 23]. All specifications for machine operation and personnel qualifications must be complied with.
  - / Children are prohibited from operating the clamping unit. Personnel in training may only work under the supervision of qualified personnel ► 2.3 [□ 8].
  - / The clamping unit may only be used in conjunction with third-party devices and components, software, tools and auxiliary materials recommended or installed by the manufacturer. Any kind of interventions, adaptations and modifications to the clamping unit are expressly prohibited.
  - / The clamping unit must not be operated in explosive or flammable environments.
  - / The clamping unit must always be operated with the protective conductor connected in the power cable.
  - / The following specifications for the electrical supply must be observed:

|                     |           |          |
|---------------------|-----------|----------|
| ▲ (E) Europe        | 230 V±10% | 50 Hz    |
| ▲ (A) North America | 115 V±10% | 60 Hz    |
| ▲ (J) Japan         | 100 V±10% | 50-60 Hz |

- / The operating front of the clamping unit must be freely accessible. It must be possible for the emergency-off push button to be actuated by the operator at any time.
- / The minimum distance of the operating front to other machines, parts of the building or internal traffic routes must be at least 1 m. A maximum ground gradient/slope of 1% must not be exceeded. During servicing/maintenance, the clamping unit must be accessible from all sides with a minimum distance of 1 m. The clamping unit is operated standing, with two hands.
- / The clamping unit is designed for use in closed, dry (max. relative humidity 95%) rooms with temperatures between +10 °C and +40 °C. The workstation must be well lit.

## 2.3 Requirements for the machine operator

The requirements for the machine operator are described below, taking into account the operating modes. Regardless of their qualifications, only staff who can reliably carry out the work assigned to them are considered. Persons under the influence of impairing agents, e.g. drugs, alcohol, medication, etc., are considered to be unreliable personnel.

### Operating mode:

|  |   |
|--|---|
| <b>Transport</b>                           | This work must be carried out by technical specialists or qualified personnel (section ► 2.3.1 [□ 8]).  |
| <b>Start-up</b>                            | This work can be carried out by the operating personnel (section ► 2.3.2 [□ 9]).  |
| <b>Normal operation</b>                    | This work can be carried out by the operating personnel (section ► 2.3.2 [□ 9]).  |
| <b>Troubleshooting and problem solving</b> | In "simple" cases, this work may be carried out by the operating personnel (section ► 2.3.2 [□ 9]). "Simple cases" are all cases that are listed in the finite list "Normal operation" (section ► 2.3.3 [□ 9]). In all other cases, the work must be carried out by technical specialists or qualified personnel (see section ► 2.3.1 [□ 8]). "Repair work" (section ► 2.3.4 [□ 9]) contains a non-exhaustive list that summarizes the relevant work steps. |
| <b>Servicing and maintenance</b>           | Same as "Troubleshooting and problem solving"   |
| <b>Disassembly and disposal</b>            | This work must be carried out by technical specialists or qualified personnel (section ► 2.3.1 [□ 8]).  |

### 2.3.1 Definition of skilled worker

These personnel must be familiar with the applicable requirements (duty of care, security, etc.) or must be sensitised accordingly by the client. The term 'specialist' therefore refers to someone who has undergone technical training, possesses the knowledge and experience necessary for the work and is capable of completing the tasks assigned to them and recognizing any potential dangers themselves.

All repair work must be carried out by employees of the company REGO-FIX or by employees of a third party commissioned by the company REGO-FIX by default. A different procedure is only possible in individual cases by agreement with customer support and with written confirmation.





### 2.3.2 Definition of operating personnel

The operating personnel must have completed system training (trained personnel). In addition to operation, this also includes an understanding of the residual risks and the resulting hazards during operation. The training may be carried out by the company REGO-FIX, a recognized sales partner of REGO-FIX or a third party commissioned by the company REGO-FIX.

### 2.3.3 Work steps/machine interactions in normal operation

- // Press the control elements on the front (operating button, emergency-off) and the toggle switch on the rear. Connecting and disconnecting the appliance plug (power supply to the machine).
- // Actuating the locking device on the pressing head to open/close the pressing area. Inserting the toolholder incl. collet and tool.
- // Actuating (pulling out/pushing in) the locking bolt (rotational movement of the pressing head).
- // Rotate the press head  $\pm 180$  degrees (clockwise or counterclockwise) to switch between clamping mode and unclamping mode of the machine.
- // Carrying out simple maintenance measures. These include:
  - / Cleaning the outside of the machine (casing elements)
  - / Clean the pressing area (machine disconnected from the power supply).
  - / Check the oil level and replenish hydraulic oil if necessary. Only for this purpose may the casing (cover and rear panel) be removed by the operating personnel. (Machine disconnected from power supply).

### 2.3.4 Repair work (by qualified personnel)

Repair operations include the following activities:

- // All work steps/machine interactions of nominal operation
- // Carrying out test runs/function tests with a reduced number of casing elements and, if necessary, with extended equipment (e.g. measuring equipment). Before carrying out any maintenance or repair work, the machine must be safely disconnected from the electrical power supply. If this is not possible (e.g. for certain fault evaluations), the work must be carried out by electrically trained personnel specifically for this type of repair work.
- // Removal of the casing elements and replacement of machine components.
- // Inspection and acceptance of the machine.

## 2.4 Identification of residual hazards

Using technical products can be dangerous. Hazards that could not be eliminated by design measures or protective devices are declared by the manufacturer as residual risks. The safety information in these operating instructions refers to the known residual risks that have been identified and classified by the manufacturer as part of risk assessment/risk reduction. If any additional dangers come to light during operation, the operator is required to reports these immediately to the manufacturer.

The residual risks vary depending on the type of operation. For this reason, the residual risks are addressed in this document for each mode of operation in section ► 4 [10 23].





The warning notices in the operating instructions warn of hazards with regard to the above-mentioned residual risks, which must be observed when handling the machine. The format used in this instruction manual for the uniform signalling of "DANGER," "WARNING," "CAUTION" and "NOTE" is shown in section ► 2.5 [10 10].

## 2.5 Presentation forms – warnings



|   |   |
|---|---|
| <b>DANGER</b>   | Hazard with a <b>high degree of risk</b> which, if not avoided, may result in <b>death or irreversible injury</b> .   |
| <b>WARNING</b>  | Hazard with a <b>medium level of risk</b> which, if not avoided, may result in a <b>reversible injury with temporary incapacity to work</b> .                     |
| <b>CAUTION</b>  | Hazardous situation with a <b>low level of risk</b> which, if not avoided, may result in a minor or <b>moderate injury without temporary incapacity to work</b> . |
| <b>NOTE</b>   | A <b>potentially harmful situation</b> that can lead to material damage.  |
| <b>NOTE</b>   |   |
|  | This symbol serves both, general information and to indicate possible material damage.  |





The following mandatory signs are used:



| <b>Symbol</b>   | <b>Meaning</b>      | <b>Symbol</b>   | <b>Meaning</b>      |
|---|---------------------|---|---------------------|
|  | Wear eye protection |  | Use safety gloves   |
|  | Use safety shoes    |  | Use head protection |

## 2.6 Residual risks of the different operating modes

| Pictogram<br>Description of residual risk   | Countermeasure  | Operating modes       |                  |                     |                       |                      |  |
|---|---|-----------------------|------------------|---------------------|-----------------------|----------------------|--|
|   |   | Transport<br>Start-up | Normal operation | Fault/rectification | Servicing/maintenance | Disassembly/disposal |  |
| <b>⚠ DANGER ⚠</b>   |   |                       |                  |                     |                       |                      |  |
| <br><b>Danger due to dangerous electric voltage</b><br>(Fatal) electric shock  | // Only operate the machine with the protective conductor connected<br>// Only operate the machine with complete casing<br>// Observe the manufacturer's specifications for the power supply            | •                     | •                | •                   | •                     | •                    |  |
|   | // Only operate the machine with the protective conductor connected<br>// Observe the manufacturer's specifications for the power supply<br>// Repair/component replacement only by qualified personnel |                       |                  | •                   |                       |                      |  |
| <b>⚠ DANGER ⚠</b>   |   |                       |                  |                     |                       |                      |  |
| <br><b>Hazards due to flammable substances</b><br>Fire   | // Regularly check tank for leaks<br>// Preventing the tank from leaking or stopping it as quickly as possible<br>// Avoid proximity to sources of fire or sparks                                       | •                     | •                | •                   | •                     | •                    |  |
|   | // Regularly check tank for leaks<br>// Avoid proximity to sources of fire or sparks<br>// Repair/component replacement only by qualified personnel   |                       |                  | •                   |                       |                      |  |
| <b>⚠ DANGER ⚠</b>   |   |                       |                  |                     |                       |                      |  |
| <br><b>Danger due to falling machine/ packaging</b><br>Crushing of parts of the body, being struck by heavy weight | // Wearing protective equipment: Protective gloves and helmet<br>// Transport with the aids provided<br>// Observe the transport instructions   | •                     |                  |                     |                       |                      |  |

| Pictogram<br>Description of residual risk  | Countermeasure   | Operating modes |          |                  |                     |                       |
|--|--|-----------------|----------|------------------|---------------------|-----------------------|
|  |  | Transport       | Start-up | Normal operation | Fault/rectification | Servicing/maintenance |
| <b>⚠ WARNING ⚠</b>   |  |                 |          |                  |                     |                       |
| <br><b>Hazards due to the use of incorrect spare parts</b><br>Different consequences due to lack of compatibility | // Only use original parts from the manufacturer<br>// Repair/component replacement by qualified personnel only<br>// If you have any questions or doubts, contact specialists and/or the manufacturer   |                 |          |                  | • •                 |                       |
| <b>Risk due to non-compliance with personnel qualifications</b><br>Improper handling or ignorance can lead to significant personal injury and/or property damage                                   | // Observe required personnel qualifications<br>// Repair/component replacement only by qualified personnel<br>// If you have any questions or doubts, contact specialists and/or the manufacturer   | •               | •        | •                | •                   | •                     |
| <b>Risk of oil splashing out</b><br>In particular, eye injuries  | // Only operate the machine when it is complete and adhere to maintenance cycles<br>// Observe the required personnel qualifications. Repair/component replacement only by qualified personnel<br>// If you have any questions or doubts, contact specialists and/or the manufacturer<br>// Wear protective equipment (safety goggles) for repairs |                 | •        | •                | •                   | •                     |
| <b>Danger due to unexpected start-up</b><br>Different consequences due to a lack of willingness  | // Ensure mains disconnection by pulling out the power supply<br>// Carry out maintenance work only on a machine that is disconnected from the power supply<br>// Repair/component replacement only by qualified personnel   |                 | •        | •                | •                   | •                     |

| Pictogram<br>Description of residual risk   | Countermeasure   | Operating modes |          |                  |                     |                       |                      |
|---|--|-----------------|----------|------------------|---------------------|-----------------------|----------------------|
|   |  | Transport       | Start-up | Normal operation | Fault/rectification | Servicing/maintenance | Disassembly/disposal |
| <b>Stopping the machine in an emergency</b><br>Different consequences due to lack of opportunity  | // No visual barrier for the emergency-off push button on the operating front<br>// Press emergency-off push button (followed by mech. reset necessary)<br>// Repair/component replacement only by qualified personnel |                 | •        | •                | •                   | •                     | •                    |
| <b>Hazards due to ineffective safety elements</b><br>Different consequences due to lack of safety   | // Only operate the machine when it is complete and adhere to maintenance cycles<br>// Repair/component replacement/adjustment of safety elements only by qualified personnel  |                 | •        | •                | •                   | •                     | •                    |
| <b>⚠ WARNING ⚠</b>  |  |                 |          |                  |                     |                       |                      |
| <br><b>Danger due to acceleration/braking</b><br>Crushing of parts of the body | // Wearing protective equipment: Protective gloves and helmet<br>// Transport of the packaging with the intended aids<br>// Observe the instructions for transporting the packaged machine                             |                 | •        |                  |                     |                       |                      |
| <b>Hazards due to moving parts</b><br>Crushing of parts of the body in pressing operation   | // Only operate the machine in complete condition, including all protective devices and parts.<br>// Observe the instructions for safe operation of the machine  |                 |          | •                | •                   | •                     | •                    |
| <b>Hazards due to moving parts</b><br>Crushing of parts of the body when inserting and removing parts   | // Close the hinged pressing head carefully<br>// Do not pinch fingers between fixed and hinged parts  |                 | •        | •                | •                   | •                     | •                    |

| Pictogram<br>Description of residual risk   | Countermeasure   | Operating modes |          |                  |                     |                       |
|---|--|-----------------|----------|------------------|---------------------|-----------------------|
|   |  | Transport       | Start-up | Normal operation | Fault/rectification | Servicing/maintenance |
| <b>⚠ CAUTION ⚠</b>  |  |                 |          |                  |                     |                       |
| <br><b>Danger due to leaking oil</b><br>Slipping   | // Follow the instructions for filling/emptying the tank<br>// Observe the maintenance cycles of the hydraulic components<br>// Repair/component replacement only by qualified personnel<br>// Wear protective equipment for repairs                                 | •               | •        | •                | •                   | •                     |
| <b>⚠ CAUTION ⚠</b>  |  |                 |          |                  |                     |                       |
| <br><b>Danger due to sharp edges/pointed areas</b><br>Cutting and puncturing                                   | // Observe the transport instructions<br>// Only operate the machine when it is complete<br>// Observe the instructions for safe operation of the machine<br>// Repair/component replacement only by qualified personnel<br>// Wear protective equipment for repairs | •               |          | •                | •                   |                       |
| <b>⚠ CAUTION ⚠</b>  |  |                 |          |                  |                     |                       |
| <br><b>Hazard due to tipping machine/packaging</b><br>Crushing of parts of the body, especially fingers/toes | // Observe the transport instructions<br>// Observe the installation location/workstation specifications<br>// Repair/component replacement only by qualified personnel<br>// Wear protective equipment for repairs  | •               |          |                  |                     |                       |
|   | // Observe the installation location/workstation specifications<br>// Repair/component replacement only by qualified personnel<br>// Wear protective equipment for repairs   | •               | •        | •                | •                   | •                     |

### 3. Device description

In section ► 3.1 [16], important components of the clamping unit are shown and named in a schematic overview. In addition, section ► 3.2 [17] shows a detailed drawing of the pressing head including important functional components. Based on the description of how the powRgrip® system works in section

► 3.3 [18], section ► 3.4 [18] provides a detailed functional description of the clamping unit.

#### 3.1 Overall view of the clamping unit

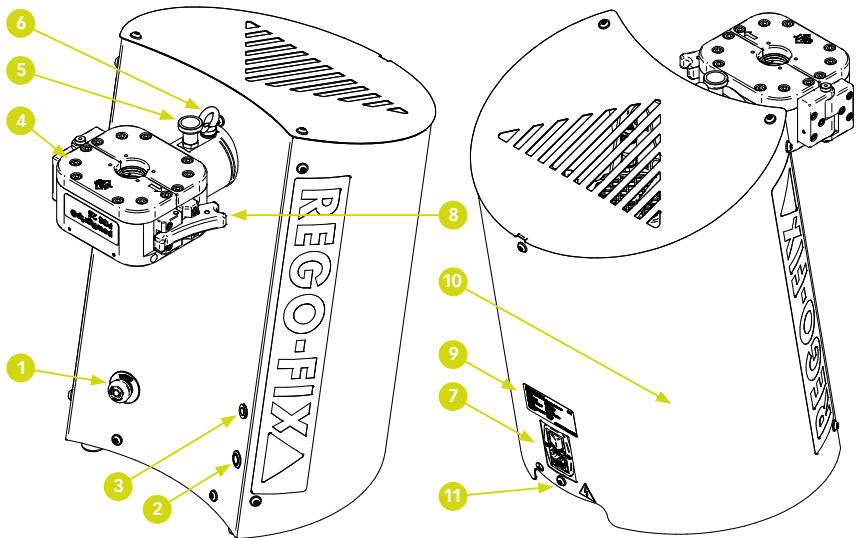

**Figure 3.1**

Schematic overview of the clamping unit including identification of important components.

|   |   |    |  |
|---|---|----|--|
| 1 | Emergency-Off push button                       | 7  | IEC socket C14                           |
| 2 | Push button with LED ring green (cycle start)   | 8  | Snap closure pressing head               |
| 3 | Red LED (display of errors)                     | 9  | Type plate                               |
| 4 | Pressing head (can be folded on one side)       | 10 | Formwork elements                        |
| 5 | Locking bolt for enabling the pivoting movement | 11 | Carrying aid for transport without crane |
| 6 | Eye bolt for transport                          |    |  |



### 3.2 Overall view of the pressing head

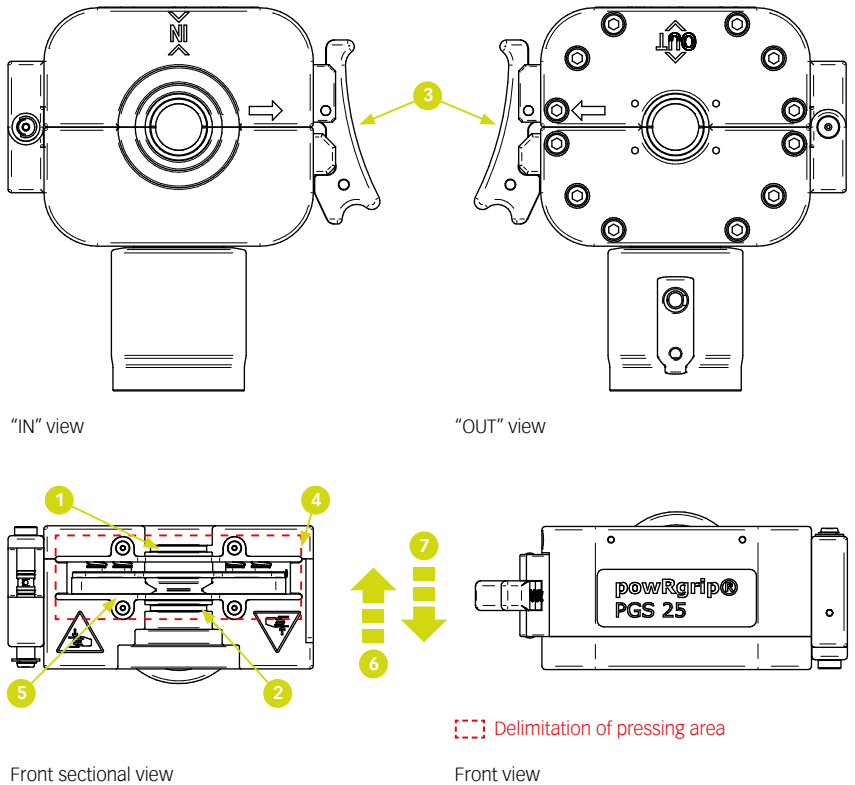

**Figure 3.2**  
Schematic overview of the pressing head incl. identification of important components.

|   |   |
|---|---|
| 1 | Support surface of toolholder Press-in  |
| 2 | Support surface of toolholder Press out |
| 3 | Snap-closure pressing head              |
| 4 | Pressing area                           |

|   |                                  |
|---|----------------------------------|
| 5 | Guard-plate pressing area        |
| 6 | Travel direction – pressing      |
| 7 | Travel direction – spring return |

### 3.3 How the powRgrip® system works

The powRgrip® tool clamping system from REGO-FIX is used for fixing cutting tools with shanks in a toolholder provided for this purpose.

- ▶ Figure 3.3 (a) [ 18] shows the three components of the powRgrip® system: toolholder, collet and cutting tool, left in the unclamped state and right in the clamped state. In addition to this,
- ▶ Figure 3.3 (b) [ 18] a sectional view of the clamping area, at the top in the unclamped state and at the bottom in the clamped state.

In order to be able to apply the necessary compressive and tensile forces for clamping and unclamping, a hydraulic assembly press from REGO-FIX is used. One of the permissible assembly presses is the clamping unit PGS 25/15/10 described in these operating instructions.

Specifications regarding shaft tolerances must be taken into account for the collets, see section 6 [ 45].

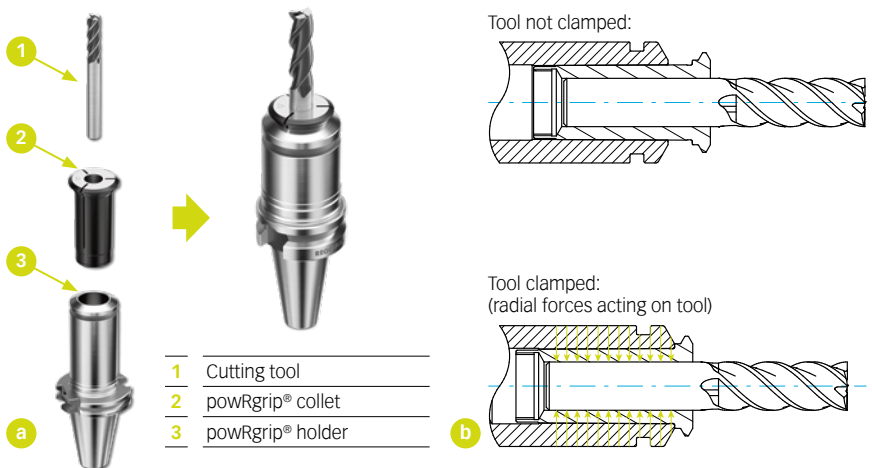

**Figure 3.3**

- a** Presentation powRgrip® system
- b** Schematic diagram clamping range

### 3.4 Functionality of the clamping unit PGS 25/15/10

The clamping unit, which is designed as a hydraulic assembly press, has an electrically operated drive unit. To switch between pressing in and pressing out, the pressing head must be turned manually by  $\pm 180^\circ$  by the operator. The current mode (clamping or unclamping) is indicated by the labels "IN" and "OUT". The direction of rotation is indicated on both sides by means of an arrow. Two bearing surfaces are provided on the inside of the pressing head, as a result of which the toolholder can be inserted and thus fixed via the groove provided for this purpose at the upper end, each pointing downwards with the spindle interface. An emergency-off push button enables the entire clamping unit to be switched off immediately and safely. To reset, the emergency-off push button must be released manually by the operator using a rotary movement. In order to be able to trigger a new pressing movement after such a stop, a start command must be given again via the LED push button provided for this purpose (cycle start).

### 3.5 Labelling

A type plate (see ► figure 3.5 [□ 19]) is attached to the rear of the clamping unit. In addition to the CE mark, it contains important information and manufacturer information.



**Figure 3.5**

Exemplary illustration of the type plate incl. identification of important components.

|   |  |    |                             |
|---|--|----|-----------------------------|
| 1 | Manufacturer and mailing address of the manufacturer | 7  | Electrical operating values |
| 2 | CE mark  | 8  | Performance                 |
| 3 | Machine type   | 9  | Operating pressure          |
| 4 | Article number                                       | 10 | Weight of the clamping unit |
| 5 | Serial number  | 11 | QR code REGO-FIX AG Website |
| 6 | Year of manufacture                                  |    |                             |

#### NOTE



For spare parts orders as well as for technical support, please supply the information provided on the type plate.

### 3.6 Specifications

| Description                               | Value           | Unit |
|---|-----------------|------|
| <b>Dimensions and weight</b>              |                 |      |
| Machine Length × Width × Height           | 531 × 406 × 591 | [mm] |
| Machine packaging Length × Width × Height | 760 × 535 × 750 | [mm] |
| Machine – Weight                          | 48              | [kg] |
| Machine with packaging – Weight           | 60              | [kg] |

|                           |            |         |
|---------------------------|------------|---------|
| <b>Benefits</b>           |            |         |
| Connected load            | 400        | [W]     |
| Engine – efficiency class | IE3        | [-]     |
| Tank size/fill quantity   | 3.5 / 2    | [l]     |
| Operating pressure (max.) | 190        | [bar]   |
| Temperature range         | +10 to +40 | [°C]    |
| Emission level            | <70        | [dB(A)] |
| Earth leakage current     | <10*       | [mA]    |

\* The clamping unit complies with product standard DIN EN 60204-1. The measured earth leakage current is less than 10 mA.  
For higher earth leakage current requirements, it is possible to connect a second protective conductor (A > 1.5 mm<sup>2</sup>) to the clamping unit (see ► figure 3.6 [□ 21]).

|  |                               |     |
|--|-------------------------------|-----|
| <b>Equipment and auxiliary materials</b>             |                               |     |
| Hydraulic oil type                                   | HLP ISO VG 32                 | [-] |
| Hydraulic oil quantity                               | 2.0                           | [l] |
| Applicable clamping equipment (depending on version) | powRgrip® PG10, PG15 and PG25 | [-] |

|  |   |     |
|--|---|-----|
| <b>Supply, interfaces, connections</b> |   |     |
| Electrical power supply                | (E) 230 V ±10% / 50 Hz<br>(A) 115 V ±10%/ 60 Hz<br>(J) 100 V ±10%/ 50-60 Hz | [-] |
| Appliance plug                         | (E) Schuko CEE-7/VI<br>Type 12 (CH)<br>(A) NEMA 5-15<br>(J) NEMA 5-15       | [-] |

View left side

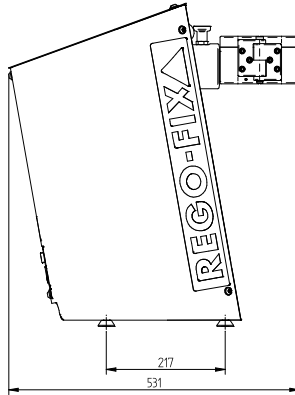

View on the right side

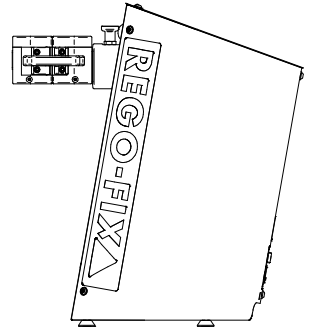

Front view

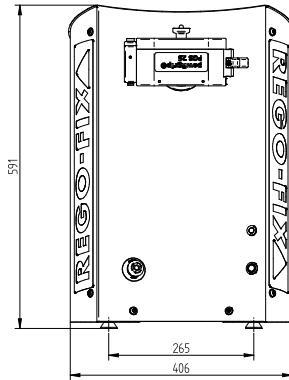

Rear view

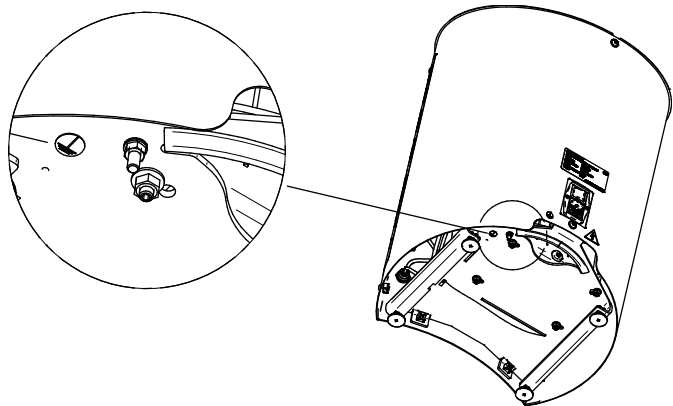
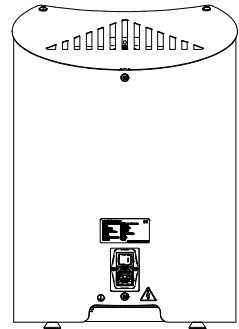

**Figure 3.6**

Dimensions of the clamping unit and connection option for a second protective conductor.

### 3.7 Delivered condition and packaging

The packaging of the machine for the first destination is carried out by the manufacturer. A packaging unit must not be overloaded or stacked. The packaging and contents must be protected from the effects of moisture and a transport temperature of between -20 °C and +40 °C must be maintained.

A schematic representation of the packaging, its dimensions and its components is shown in ► figure 3.7 (a) [ 72].

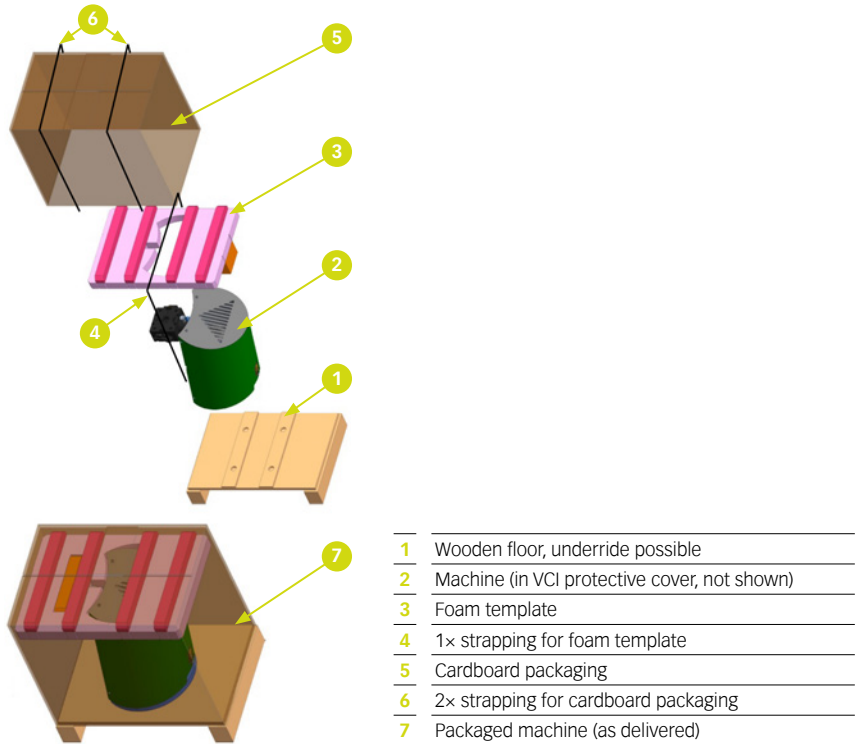





**Figure 3.7**

Schematic diagram of the packaging and the packaged machine, including identification of important components.

The following components are included in the scope of delivery:

- // 1× assembly press PGS (25/15/10) (E, A or J) for the powRgrip® clamping system
- // 1× packaging incl. VCI protective cover and matching thread tape
- // 1× original operating instructions (printed)
- // 1× country-specific power cable

| NOTE  |   |   |   |
|---|---|---|---|
|  | Even brief interim storage of the product in an aggressive humid environment can lead to corrosion or similar transport damage. |  | The packaged machine must not be stacked.             |
|  | Displays the top of the packaged machine.   |  | Protect the packaged machine/packaging from moisture. |

If transport damage is discovered during the incoming goods inspection, the following steps must be carried out:

- // Recording of transport damage in a damage report
- // Notification of the carrier of the existence and nature of the damage
- // Notification of the supplier of the existence and nature of the damage

## 4. Operating modes

The different operating modes are explained below.

### 4.1 Transport

#### 4.1.1 Personnel qualification

Technical specialists or specialist personnel are absolutely necessary for transport. More information on personnel qualification can be found in section ► 2.3 [□ 8].



#### 4.1.2 Residual risks

A list of the residual risks can be found in section ► 2.6 [□ 12].

#### 4.1.3 Description of the workstation and requirements for the installation location

The clamping unit is designed for operation on a workbench or a specially manufactured assembly unit (pay attention to weight). The clamping unit must be positioned in such a way that safe and long-lasting operation is guaranteed.



#### 4.1.4 Transport of the packaged machine

| NOTE  |  |
|---|--|
|  | <p>// Foot protection must be worn as protective equipment for transport on the ground</p> |
|  | <p>// Wearing gloves is recommended</p>  |

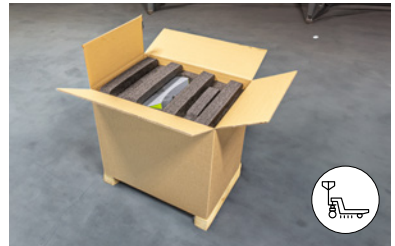
- // There is an underride option for a pallet truck
- // Ensure that the clamping unit does not tip over during lifting
- // Gently put down the pallet with the clamping unit



#### 4.1.5 Transport by crane

| NOTE  |  |
|---|--|
|   | <p>// Foot and head protection must be worn when transporting with a crane</p> |
|  | <p>// Wearing gloves is recommended</p>  |
|  |  |

| NOTE  |   |
|---|---|
|  | <p>The device may only be transported by crane without a toolholder or cutting tool (risk of injury).</p> |



**Step 1:**

If necessary, fix the eye bolt in place. Use two washers (as delivered).

Pull the thread band, supplied, through the eye bolt and fasten to the crane mount.

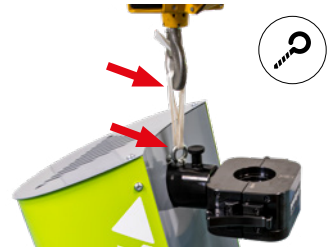
**NOTE**

The thread band may only be used for this purpose and for this device.

**Step 2:**

Slowly lift the machine with the crane, transport it to the desired position and set it down gently.

Avoid swings and sudden changes of direction.

Remove the thread band and save for later use.

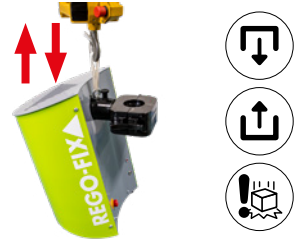
**Step 3:**

If desired, the eye bolt can be removed for machine operation.

In the event of a later transport, the eye bolt and the two washers as well as the thread band must be kept at the machine.

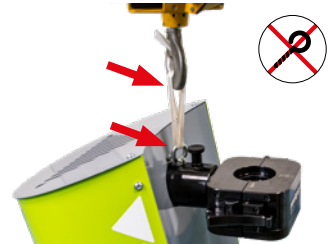
**4.1.6 Transport by hand**

The following instructions show how the machine has to be transported by two people without aids and which specifications must be observed.

**NOTE**

// Foot protection must be worn as protective equipment during transport



// Wearing gloves is recommended

## ⚠ WARNING ⚠



- // The device may only be transported by hand by two persons without a toolholder and cutting tool inside the device (risk of injury).
- // Heavy equipment (48 kg)
- // Tilt angle. If necessary, use the yellow stopper (see section ▶ 4.2.3 [ 27]). Otherwise, if the device tilts too much, the ventilation filter will be filled with oil, which requires replacement.
- // Snap the snap lock and the locking bolt of the head into place for a secure grip.

### Procedure:

Read the notes and warnings above for safe transport by hand.

With the clamping unit standing on the floor or on the table, one person grasps the underside of the pressing head (front) and the other person grasps the underside of the stand unit (recess for hand).

By lifting the clamping unit together, it can be held and then transported to the desired position.

Gently set down the clamping unit at the desired position.





## 4.2 Start-up

### 4.2.1 Personnel qualification



Commissioning can be carried out by operating personnel. More information on personnel qualifications can be found in section ► 2.3 [ 8].

### 4.2.2 Residual risks

A list of the residual risks can be found in section ► 2.6 [ 12].

| NOTE  |  |
|---|--|
|  | When commissioning for the first time, replace the tank cap with the ventilation filter. (See section ► 4.2.3 [ 27])                                     |
|  | To prevent damage to the clamping equipment and the machine, a cutting tool must always be inserted when clamping powRgrip® collets (never clamp empty). |

### 4.2.3 Important information on initial commissioning

| NOTE  |   |
|---|---|
| <br> | The following protective equipment must be worn for initial commissioning:<br>Foot protection, eye protection |

General specifications must be taken into account when selecting the installation location for commissioning the clamping unit. These are set out in section ► 2.2 [ 7].

Requirements for the machine operator are described in section ► 2.3 [ 8].

The tank was filled with hydraulic oil before delivery and the entire clamping unit was checked for leaks and functionality. The tank is sealed with a yellow stopper for transport. Before commissioning the clamping unit, it must be replaced with the supplied ventilation filter.

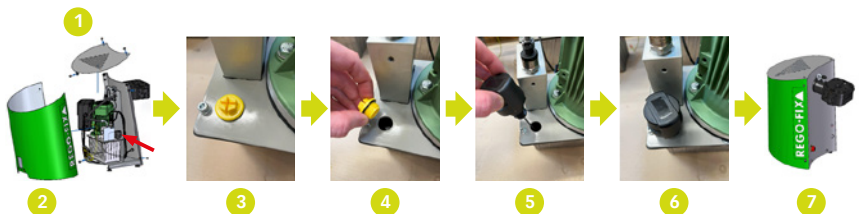

|     |   |
|-----|---|
| 1   | Remove cover  |
| 2   | Dismantle the rear panel  |
| 3+4 | Unscrew the yellow fuel cap. This serves only as a transport safeguard and can be kept for later use. |
| 5+6 | Screw in the black ventilation filter.  |
| 7   | Reattach covers in reverse order. The device is now ready for use.                                    |

Transport damage is to be treated as described in section ► 3.7 [□ 22]. The duty to report lies with the user. To start up the machine, first remove the complete packaging and section ► 4.1.3 [□ 23] for the selection of the place of work/installation.

The supplied power cable is required to operate the machine. The manufacturer's requirements for the external power supply must be observed and guaranteed. Step-by-step instructions for initial commissioning are provided below.

The following elements of the machine must be visually inspected by the installation personnel and/or the user before commissioning.

**Control 1:**

Check that the power cable and the socket with fuse (10 A, 250 V) are not damaged.

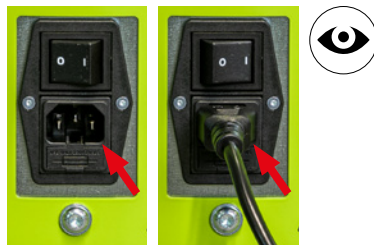

**Control 2:**

Check whether the leak-tightness of the machine is guaranteed (no leakage).



**Control 3:**

Check that the guard plates in the pressing head are fixed and complete with 4 screws each.

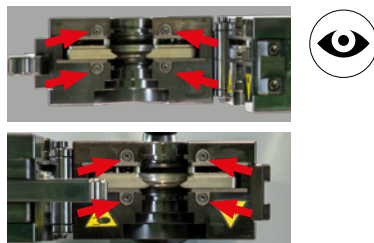

**Control 4:**

Check that the controls are not damaged and that the emergency-off push button is not actuated.

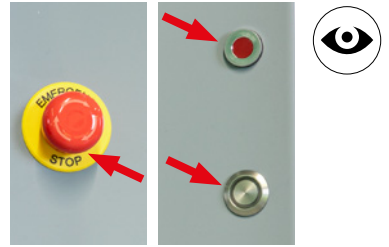
**Control 5:**

By engaging in the end positions, the locking bolt serves to securely position the pressing head. To release or swivel, pull the stop bolt. Release the locking bolt during the pivoting movement. It engages automatically when the end position is reached.

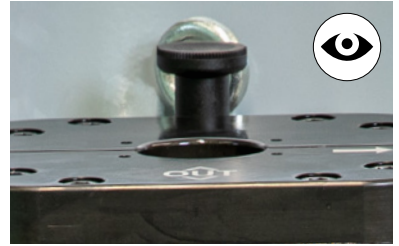
**Control 6:**

Check that all casing elements are correctly installed and that no screws are missing.

**Control 7:**

Check if the device is standing level on the selected surface. If necessary, correct the tilt of the instrument by turning the feet in/out.

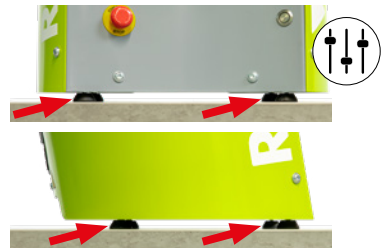

#### 4.2.4 Instructions for initial commissioning

##### Step 1:

Set up the machine at the workstation in compliance with the requirements in section ► 4.1.3 [23].



##### Step 2:

Plug the power cable into the C14 appliance plug on the rear of the appliance and connect to the external power supply.

Details about the connector can be found in section ► 3.6 [20].

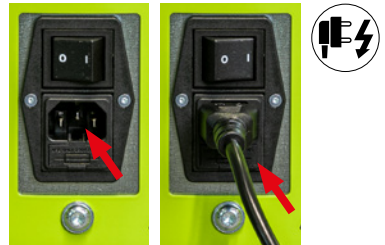

##### Step 3:

Ensure that the pressing head is closed and fixed in this position using the lateral snap-closure.

Swing the pressing head into one of the limit positions, "IN" or "OUT". The locking bolt must be fully engaged.



##### Step 4:

Switch on the clamping unit using the toggle switch (on the rear of the device).

After approx. 10 seconds, the LED button on the front lights up green. The machine is now ready for operation.

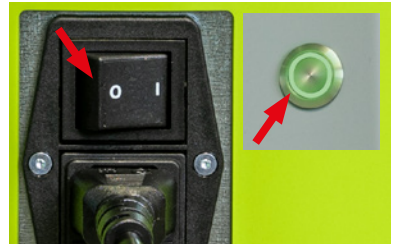

##### Step 5:

If the red LED lights up, there is an error and the clamping unit is not ready for operation. Further information about troubleshooting and problem solving can be found in section ► 4.4 [36].









## 4.3 Normal operation

### 4.3.1 Personnel qualification

Normal operation can be carried out by operating personnel. More information on personnel qualification can be found in section ► 2.3 [□ 8].

### 4.3.2 Residual risks

A list of the residual risks can be found in section ► 2.6 [□ 12].

| NOTE  |  |
|---|--|
|    | To prevent damage to the clamping equipment and the clamping unit, a cutting tool must always be inserted when clamping powRgrip® collets (never clamp empty).   |
|    | Even brief interim storage of the clamping unit in an aggressive humid environment can lead to corrosion or similar damage.  |
|    | Min./max. clamping lengths for cutting tool shafts according to specifications in section ► 6 [□ 45]. The clamped cutting tool must always rest against the adjusting screw of the collet on the rear side.  |
|    | Before each pressing-in procedure, the clamping equipment and the cutting tool to be clamped must be cleaned according to the specifications in section ► 5 [□ 44].  |
|   | The collet must be pressed into the toolholder to stop. There must be no visible gap between the collet and the toolholder. If there is a gap, in particular the maximum holding force, the transmittable torque and the concentricity can be negatively affected. |
|  | Only tool shafts with a diameter tolerance of h6 or more precisely may be clamped. Only PG-TAP collets allow diameter tolerances up to h9. Clamping tool shafts with too much undersize can permanently damage the collets.  |

### 4.3.3 Instructions for pressing in cutting tools

| <b>⚠ WARNING ⚠</b>  |  |
|---|--|
|  | <p>// During a pressing cycle, the hydraulic system is under pressure (190 bar). The pressing head may only be opened once the pressing-in process has been completed (see step 6). Forcible opening of the pressing head during the pressing process leads to damage to the equipment and increases the risk of injury.</p> <p>// In an emergency, press the Emergency-Off push button.</p> |

#### Step 1:

To press in, turn the pressing head to the stop so that the stop bolt engages and the lettering "IN" on the top is legible.



#### Step 2:

Prepare the powRgrip® clamping equipment and the cutting tool to be clamped and clean according to the specifications in section ▶ 5 [□ 44].

Specifications for the clamping length and for the tool geometry according to section ▶ 6 [□ 45].

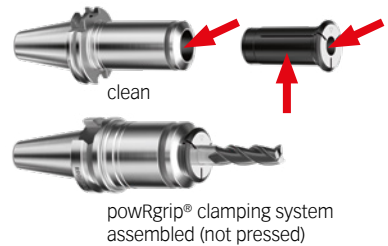

#### Step 3:

Open the pressing head and check that the pressing plates are positioned on both sides of the pressing head at the upper stop (reset by the springs).

If this is not the case → section ▶ 4.4 [□ 36] "Troubleshooting and problem solving".

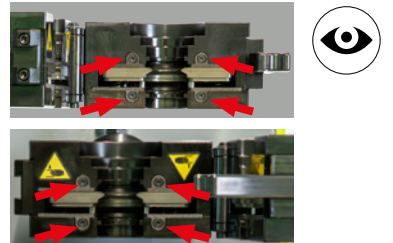

#### Step 4:

Provided the pressing plates are in the correct position, the clamping equipment and cutting tool prepared as per step 2 can be inserted into the pressing head with one hand holding. While the inserted clamping equipment is held with one hand (at the bottom end), the other hand is used to close the foldable pressing head and lock it mechanically using the snap-closure. The inserted clamping equipment can then be released.





**Step 5:**

Switch on the clamping unit using the toggle switch (on the rear of the device).

As soon as the LED button on the front lights up green after approx. 10 seconds, the clamping unit is ready for operation (standby mode).

If the red LED lights up, there is an error → section ► 4.4 [ 36] "Troubleshooting and problem solving".

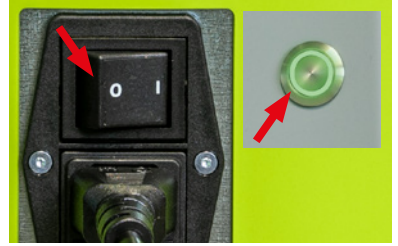
**Step 6:**

Press the push button to start the press-in cycle. During the pressing process, the hydraulic unit works audibly and the green LED flashes quickly. As soon as the pressing process is complete, the green LED flashes slowly. The clamping equipment can now be removed from the pressing head, taking into account the further steps.

If the red LED lights up constantly, there is an error → section ► 4.4 [ 36] "Troubleshooting and problem solving".

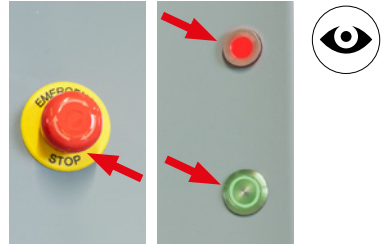
**Step 7:**

Hold the clamping equipment with one hand for removal. Then open the hinged pressing head with the other hand.

Now remove the clamping equipment and close the pressing head again until the snap lock clicks into place.

The LED button now glows steadily green, indicating the standby mode of the device. The device is ready for the next pressing process.

**Step 8:**

Check if the collet is pressed to the stop (no gap between the collet and the toolholder).

If a gap is visible, remove the collet as described in section ► 4.3.4 [ 34] and clean both the holder retainer and the collet (section ► 5 [ 44]).

Then repeat the clamping process.

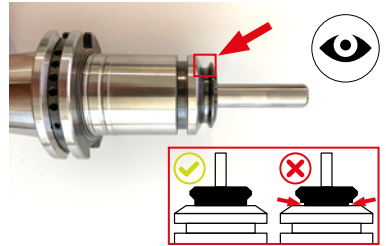

#### 4.3.4 Instructions for pressing out cutting tools

| <b>⚠ WARNING ⚠</b>  |  |
|---|--|
|  | <p>// During a pressing cycle, the hydraulic system is under pressure (190 bar). The pressing head may only be opened once the pressing-in process has been completed (see step 5). Forcible opening of the pressing head during the pressing process leads to damage to the equipment and increases the risk of injury.</p> <p>// In an emergency, press the Emergency-Off push button.</p> |

##### Step 1:

To press out, turn the pressing head to the stop so that the stop bolt engages and the label "OUT" on the top is legible.



##### Step 2:

Open the pressing head and check that the pressing plates are positioned on both sides of the pressing head at the lower stop (reset by the springs).

If this is not the case see → section ▶ 4.4 [ 36] "Troubleshooting and problem solving".

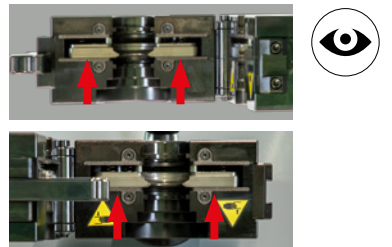

##### Step 3:

Provided the pressing plates are in the correct position, the holder with the cutting tool to be pressed can be inserted into the pressing head with one hand. Close the pressing head with the other hand until it is mechanically locked by means of the snap-closure.

The inserted clamping equipment can then be released.

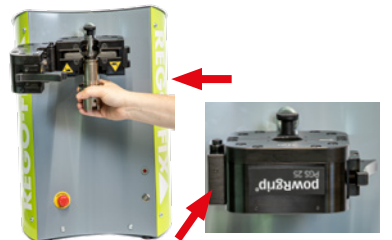

##### Step 4:

Switch on the clamping unit using the toggle switch (on the rear of the device).

As soon as the LED button on the front lights up green after approx. 10 seconds, the clamping unit is ready for operation (standby mode).

If the red LED lights up, there is an error see → section ▶ 4.4 [ 36] "Troubleshooting and problem solving".



---

**Step 5:**

Press the push button to start the pressing-out cycle. During the pressing process, the hydraulic unit works audibly and the green LED flashes quickly.

As soon as the pressing process is complete, the green LED flashes slowly. The clamping equipment can now be removed from the pressing head, taking into account the further steps.

If the red LED lights up constantly, there is an error → section ▶ 4.4 [ 36] "Troubleshooting and problem solving".

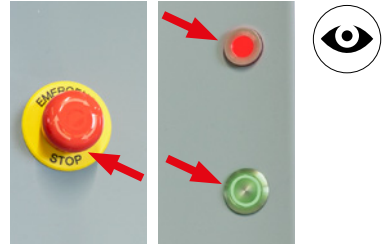

---

**Step 6:**

Hold the clamping equipment with one hand for removal. Then open the hinged pressing head with the other hand.

Now remove the clamping equipment and close the pressing head again until the snap-closure clicks into place. The LED button now glows steadily green, indicating the standby mode of the device. The device is ready for the next pressing process.



---

**Step 7:**

Remove the released collet and tool from the tool-holder one after the other.

Before the next clamping, observe the cleaning specifications in section ▶ 5 [ 44].

Protect against corrosion during storage.

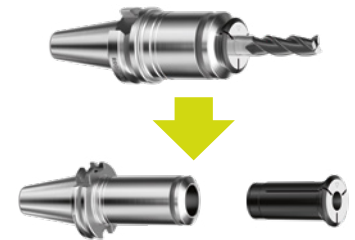

#### 4.3.5 Decommissioning of the clamping unit

In the event of a brief interruption (e.g. overnight or over the weekend), the main switch of the clamping unit must be switched off.

The following points must be observed if the clamping unit is not used for a prolonged period of time, during machine maintenance or a planned machine transport:

// Switch off the main switch of the clamping unit

// Disconnect the main plug of the clamping unit (main disconnect device)

// It must be ensured that there is no pressure on the system. This can be assessed by the fact that the springs installed in the pressing head are in the extended state and, accordingly, the pressing plates are in the rest position (stop with respect to the springs).

The following points must be observed when shutting down the clamping unit:

// The procedure is the same as for long periods of non-use. In addition, the hydraulic oil must be removed from the tank and the system and disposed of properly.

### 4.4 Troubleshooting and problem solving

#### 4.4.1 Personnel qualification

Troubleshooting and problem solving can be carried out by operating or specialist personnel. More information on personnel qualification can be found in section ► 2.3 [□ 8].

#### 4.4.2 Residual risks

A list of the residual risks can be found in section ► 2.6 [□ 12].

#### 4.4.3 Display of errors/faults

As soon as an error/fault occurs, the red LED is permanently lit. At the same time, the green LED starts flashing in a specific flashing pattern. The type of error present can be derived from the latter.

Actuating the Emergency-Off push button does not cause an error, as in this case the power supply is disconnected. As a result, the machine is depressurized. As soon as the situation allows the device to continue to be operated, the Emergency-Off push button must first be mechanically released and a new press-in/press-out triggered by pressing the LED-button ("Start cycle").







## NOTE



This section outlines some error cases and measures to remedy them. However, detailed repair instructions, especially for defective components, are not included here, as these repairs must be carried out by appropriate specialist personnel.



#### 4.4.4 Error messages

To locate the cause of the error for the first time, a distinction is made between 3 error categories using the green LED (flashing pattern).

| Green LED   | Red LED  | Error message   |
|---|--|---|
| <p data-bbox="378 162 468 181">Flashes 3x</p>  <p data-bbox="344 237 501 256">(Flashing pattern 1)</p> | <p data-bbox="698 162 788 181">Permanent</p>  | <p data-bbox="874 162 1059 181">Sensors pressing head</p> |
| <p data-bbox="378 290 468 309">Flashes 4x</p>  <p data-bbox="344 365 501 384">(Flashing pattern 2)</p> | <p data-bbox="698 290 788 309">Permanent</p>  | <p data-bbox="874 290 990 309">Pressing force</p>         |
| <p data-bbox="378 418 468 437">Flashes 5x</p>  <p data-bbox="344 493 501 512">(Flashing pattern 3)</p> | <p data-bbox="698 418 788 437">Permanent</p>  | <p data-bbox="874 418 997 437">Control system</p>         |

#### 4.4.5 Error message – Sensors pressing head (flashing pattern 1)

A proximity sensor is installed in the pressing head, which enables the machine control system to check whether the pressing head is open or closed. The presence of a related error is signaled as follows:



| Green LED   | Red LED  | Error message         |
|---|--|-----------------------|
| Flashes 3x<br><br>(Flashing pattern 1) | Permanent<br> | Sensors pressing head |



| Possible cause   | Remedy   | Qualification        |
|--|--|----------------------|
| Start of the pressing cycle with the pressing head open/not completely closed.   | Close the pressing head and acknowledge the error by pressing "Start cycle".<br><br>Initiate a new pressing procedure after acknowledging by pressing "Start cycle" again.   | Operating personnel  |
| Door is opened during pressing cycle. The pressing process is interrupted when it is opened. A return of the pressing plate is brought about by the springs.   | Close the pressing head and acknowledge the error by pressing "Start cycle".<br><br>Initiate a new pressing procedure after acknowledging by pressing "Start cycle" again.<br><br>Check all equipment for possible damage. | Operating personnel  |
| Error cannot be rectified by acknowledgement.<br><br>The proximity sensor may be defective.<br><br>Other causes include a defective control system or errors/damage in the machine wiring.   | Enquiry support distributor or manufacturer for repair.  | Specialist personnel |
| Error cannot be rectified by acknowledgement.<br><br>The proximity sensor works, but is not actuated correctly, e.g. because the contact is no longer reliable.<br><br>This can happen, for example, if the screws on the snap lock of the pressing head have been loosened and are not correctly reassembled. | Tighten the screws on the snap lock and adjust if necessary.   | Operating personnel  |

| Possible cause  | Remedy   | Qualification        |
|---|--|----------------------|
| The pressing head cannot be closed or can no longer be completely closed. | Chips or similar material trapped between the two halves of the hinged pressing head.<br>→ Clean.  | Operating personnel  |
|   | Damage to the guard-plates, which means that the pressing head can no longer be closed, as at the top, or that the toolholder can no longer be fully inserted. → Enquiry support distributor or manufacturer for repair. | Specialist personnel |

#### 4.4.6 Error message – Pressing force (flashing pattern 2)



When a clamping or unclamping process is started, pressure is built up by the hydraulic system. If this pressure is not reached within a specified period of time, an error message appears. The presence of a related error is signaled as follows:

| Green LED   | Red LED  | Error message  |
|---|--|----------------|
| Flashes 4x<br><br>(Flashing pattern 2) | Permanent<br> | Pressing force |

| Possible cause   | Remedy   | Qualification        |
|--|--|----------------------|
| There is too little hydraulic oil in the tank of the clamping unit. The pressure cannot be built up. | Top up hydraulic oil.<br><br>Only when disconnected from the power supply.    | Operating personnel  |
| The hydraulic oil is too dirty and must be replaced.   | Replace hydraulic oil.<br><br>Only when disconnected from the power supply. | Specialist personnel |
| It is possible that air has entered the hydraulic circuit.   | De-airing the system.<br><br>Risk of eye injury when unscrewing the screws. | Specialist personnel |
| Possibly defective electrical components   | Troubleshooting and replacement of defective (sub-) components.  | Specialist personnel |

#### 4.4.7 Error message – control system (flashing pattern 3)

The machine is controlled by a frequency converter with a programmable logic controller (PLC). The presence of a related error is signaled as follows.

| Green LED   | Red LED  | Error message         |
|---|--|-----------------------|
| <p>Flashes 5x</p>  <p>(Flashing pattern 3)</p> | <p>Permanent</p>  | <p>Control system</p> |

Only the origin of the fault (frequency converter) can be evaluated from the flashing pattern, but no further details about the type of fault. For more details, the control unit must be read out by qualified personnel.

However, since the cause of such a fault is often related to the electrical power supply and the ambient conditions, some measures that can be carried out by the operating personnel are listed below.

| Possible cause  | Remedy  | Qualification                             |
|---|---|---|
| There may be an overvoltage or undervoltage.  | Compliance with the specifications for the electrical power supply:<br><br>(E) 230 V $\pm$ 10% / 50 Hz<br>(A) 115 V $\pm$ 10%/ 60 Hz<br>(J) 100 V $\pm$ 10%/ 50-60 Hz | Operating personnel                       |
| Residual current circuit breaker (FI) reacts.   | Design infrastructure for a maximum earth leakage current of <10 mA.  | Operating personnel, specialist personnel |
| The (ambient) temperatures may be too high/too low.   | Compliance with temperature specifications.<br><br>+10°C to +40°C   | Operating personnel                       |
| It is possible that the pressure sensor is defective, does not give a signal or is not connected correctly. | Support enquiry from sales partner or manufacturer, if necessary check and replace defective parts.   | Specialist personnel                      |
| There may be an internal fault of the frequency inverter.   | Support enquiry from sales partner or manufacturer, if necessary check and replace defective parts.   | Specialist personnel                      |

### NOTE



For spare parts orders as well as for technical support, please supply the information provided on the type plate.





#### 4.4.8 Other errors without flashing pattern

| Possible cause  | Remedy  | Qualification               |
|---|---|-----------------------------|
| <p>An error occurs, but the red LED does not indicate an error.</p> <p>The red LED is defective.</p>  | <p>Enquiry support distributor or manufacturer for repair.</p>  | <p>Specialist personnel</p> |
| <p>A tool cannot be clamped or released despite correctly built-up pressure.</p> <p>Faulty or dirty clamping equipment.</p>   | <p>Clean the clamping equipment and check the specifications for the clampable tools.</p>   | <p>Operating personnel</p>  |
| <p>The pressing plates are no longer reset by the springs after a pressing cycle (remain stuck in the upper/lower end position).</p> <p>Soiling or damage to guides/springs can result in this.</p> | <p>Reset the pressing plate by light blows with the rubber hammer (from above).</p> <p>Then clean the guides of dirt and abrasion.</p> <div data-bbox="557 647 927 687" style="background-color: red; color: white; text-align: center; padding: 5px;"> <b>DANGER</b> </div> <p>Since the guard plates on the pressing head may have to be removed for this purpose, this cleaning work may only be carried out in a state that is disconnected from the power supply.</p> <div data-bbox="557 831 927 871" style="background-color: red; color: white; text-align: center; padding: 5px;"> <b>DANGER</b> </div> <p>The guard plates must not be removed before the pressing plate is reset with the rubber hammer, as there is a risk of crushing even when the power supply is disconnected (non-controlled reset).</p> | <p>Operating personnel</p>  |

## 4.5 Servicing and maintenance

### 4.5.1 Personnel qualification

Maintenance and servicing work can be carried out by operating or qualified personnel. More information on personnel qualification can be found in section ► 2.3 [▢ 8].

### 4.5.2 Residual risks

A list of the residual risks for the “Maintenance and maintenance” mode can be found in section ► 2.6 [▢ 12].

### 4.5.3 Maintenance schedule

Various maintenance and servicing tasks have to be performed in order to maintain safe operation of the clamping unit. Details of individual servicing and servicing work, including information on the time intervals, are given below. This information relates to a single-shift operation and must be adapted or shortened accordingly in the case of multi-shift operation. All maintenance and servicing tasks must always be carried out while the machine is at a standstill (mains is disconnected and the system is depressurised).

| Component                                     | Inspection/replacement                                | Inspection/maintenance task   | Qualification        |
|---|---|---|----------------------|
| Clamping equipment (holder and clamping tool) | Before each pressing-in process                       | Clean according to the instructions in section ► 5 [▢ 44].                            | Operating personnel  |
| Screw connections in general                  | Ongoing   | In general, pay attention to loose parts and unusual noises, especially when tilting. | Operating personnel  |
| Instrument cladding and pressing area         | Weekly  | Clean with a soft cloth and all-purpose cleaner.                                      | Operating personnel  |
| Pressing head                                 | Ongoing or weekly                                     | Increased occurrence of oil indicates leaks.  | Operating personnel  |
| Hydraulic unit                                | Ongoing or annually                                   | Visual inspection of hydraulic unit and lines for leaks.                              | Specialist personnel |
| Tank and ventilation filter                   | Check weekly, replace annually                        | Visual check of the oil level of the tank and the ventilation filter.                 | Specialist personnel |
| Hoses and fittings                            | Check annually, replace hydraulic hoses every 5 years | Check hoses and fittings for leaks. If necessary, change the hydraulic components.    | Specialist personnel |

## 4.6 Disassembly and disposal

### 4.6.1 Personnel qualification

Disassembly and disposal must be carried out by qualified personnel. Further information on personnel qualification can be found in section ► 2.3 [8].

### 4.6.2 Residual risks

A list of the residual risks can be found in section ► 2.6 [12].

#### NOTE



Observe local disposal regulations.

## 5. powRgrip® cleaning instructions



1 Insert cleaning paper into the slot of the taper cleaner from the front. Allow enough paper to cover the whole width of the slot. Push down towards the flange until completely seated.



2 Bend paper over and wrap around the taper cleaner.



3 Hold paper with thumb.



4 Insert taper cleaner fully into the collet cavity of the toolholder. Turn to wipe clean.



5 Degreasing / cleaning powRgrip® collet. Dip in clean, oil soluble solvent, (e.g. alcohol, cold cleaner).

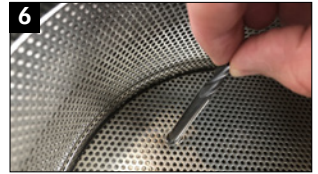

6 Clean tool shank by dipping in clean, oil soluble solvent, (e.g. alcohol, cold cleaner).



7 Dry off solvent with oil-free compressed air. Insert tool into collet.



8 Insert tool into collet. Insert toolholder assembly into powRgrip® unit and press in collet.

Only use this specially prepared, soft and absorbent cleaning paper. **For one time use only!**

**!** Do not press in the collet without a tool. Pressing in collets without a tool will destroy the collet!

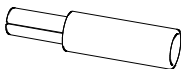

TKCP Taper cleaner

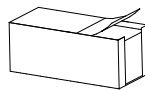

CPS Cleaning paper set

## 6. Technical data powRgrip®

Further user information, such as clamping lengths and cleaning guidelines, is available via QR code.



## 7. Spare parts

For more information on wearing parts and spare parts, please contact your dealer or manufacturer with the serial number.

| Position | Part no.  | Description                   |
|----------|-----------|-------------------------------|
| 11       | 600009702 | Flat gasket for tank          |
| 20       | 600009704 | Ventilation filter            |
| 100      | 600009706 | Electric motor                |
| 101      | 600009708 | Frequency converter           |
| 110      | 600009711 | Pump                          |
| 111      | 600009713 | Pump support plate seal       |
| 120      | 600009715 | Pump housing                  |
| 121      | 600009717 | Pump support plate seal       |
| 201      | 600009719 | Flat gasket Block             |
| 210      | 600009721 | Pressure relief valve         |
| 220      | 600009723 | 3/2-way valve                 |
| 300      | 600009725 | Pressure transmitter          |
| 450      | 600009727 | Tube L = 220 mm               |
| 700      | 600009729 | Tube L = 550 mm               |
| 710      | 600009731 | WEO socket                    |
| 810      | 600009733 | Emergency-off button          |
| 820      | 600009735 | Emergency-off Labelling plate |
| 830      | 600009737 | Signal lamp LED red           |
| 840      | 600009739 | Switch LED green              |
| 850      | 600009741 | On/off switch                 |
| 860      | 600009743 | Socket                        |
| -        | 767844710 | Eye bolt ISO3266-M8           |
| -        | 031000164 | Washer eye bolt               |
| -        | 600006685 | Locking bolt M16x15-D8        |
| -        | 032003696 | PGS 25 Immersion plate        |
| -        | 032002970 | PGS 10/15/25 Fixed foot M6    |
| -        | 032003580 | Cover                         |
| -        | 032003581 | Front panel                   |
| -        | 032003582 | Rear plate                    |
| -        | 036200411 | REGO-FIX sticker              |

## 8. Drawings and diagrams

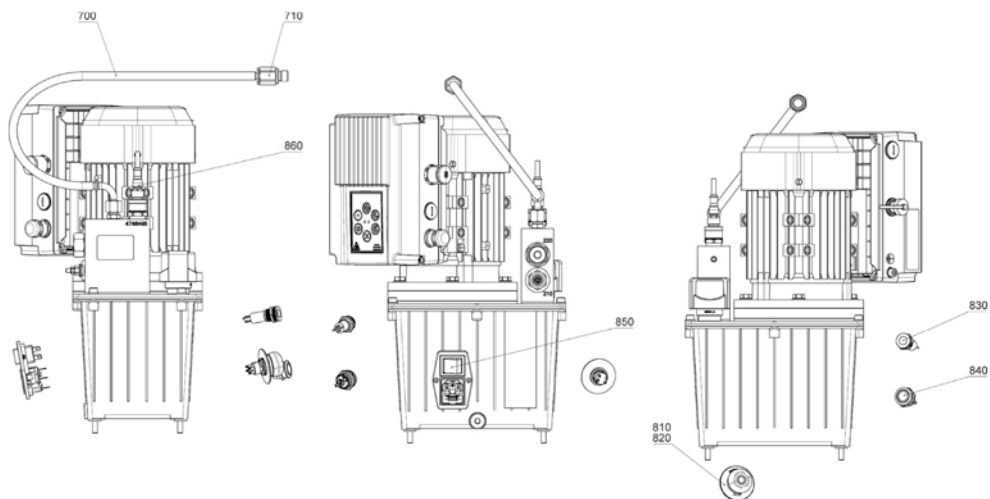

Ansicht ohne el. Komponenten

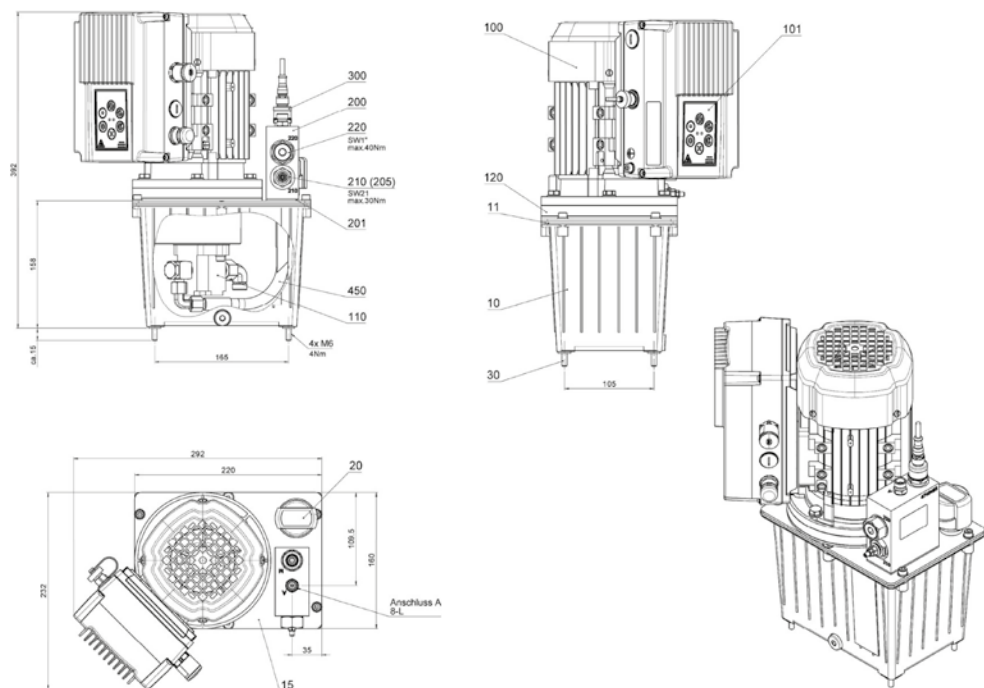

## 8.1 Hydraulic diagram

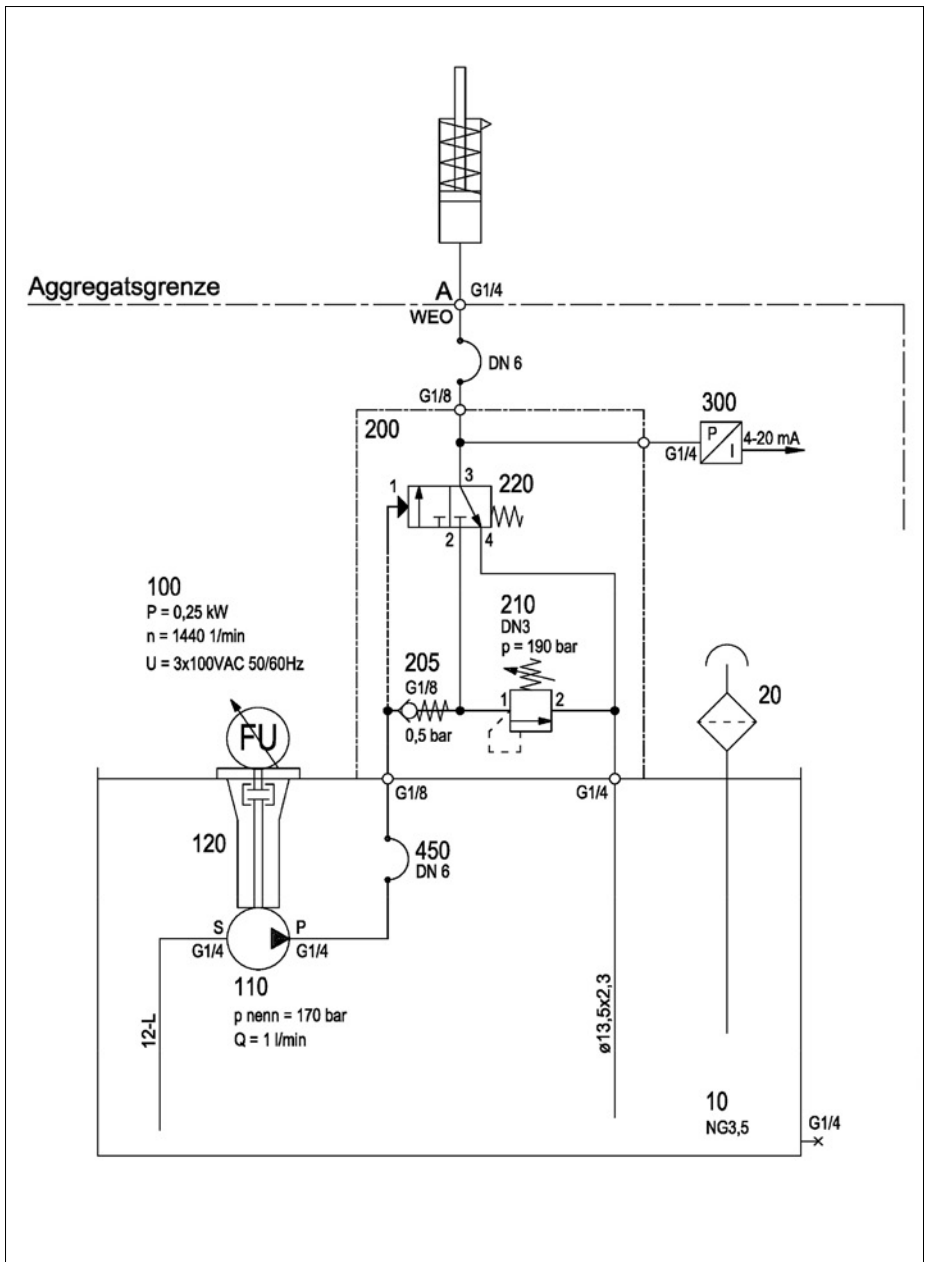







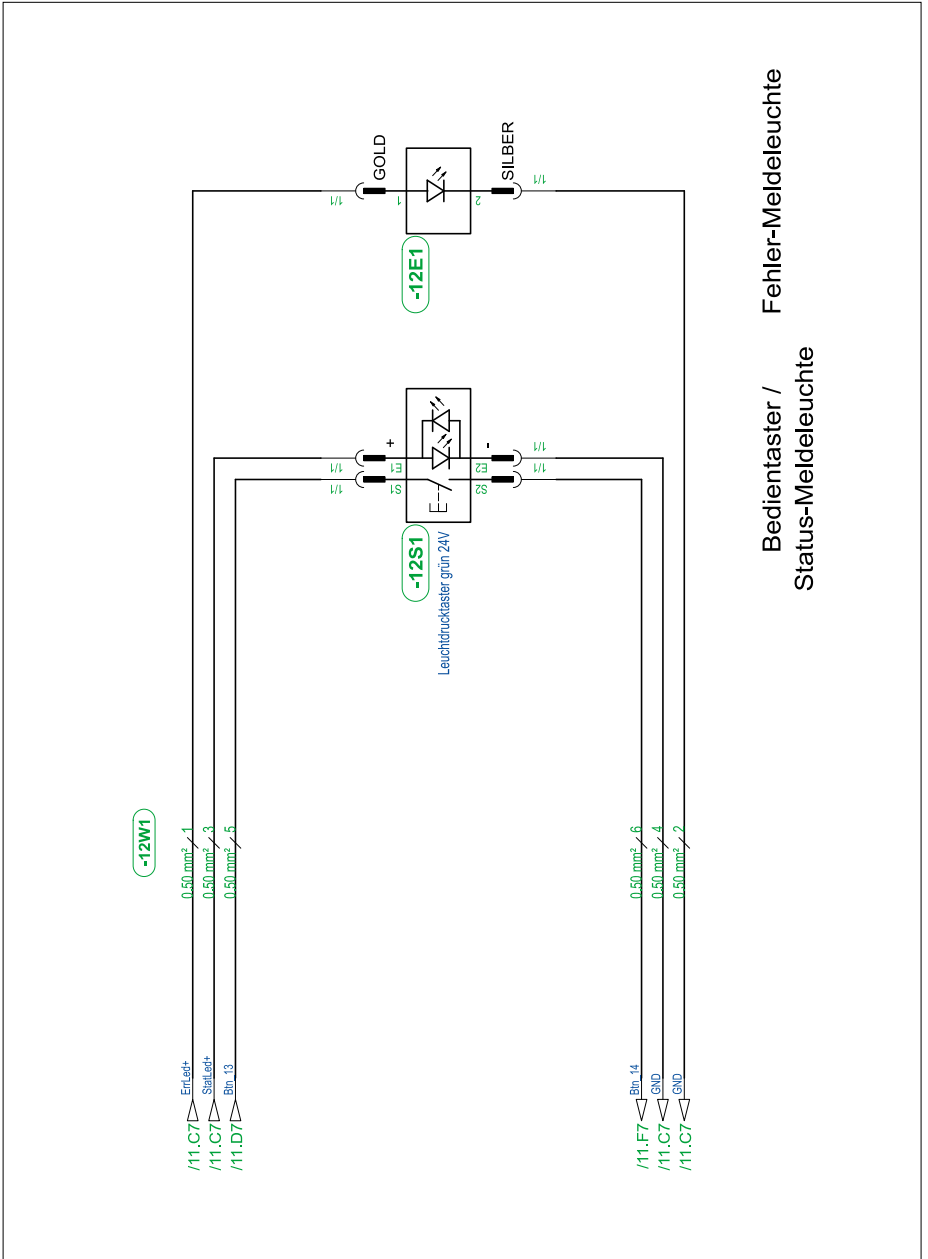

Bedientaster / Fehler-Meldeleuchte  
Status-Meldeleuchte

## 9. EC Declaration of Conformity

# EC Declaration of Conformity

The manufacturer REGO-FIX AG, Obermattweg 60, 4456 Tenniken, Switzerland hereby declares that the following machine

|               |  |
|---------------|--|
| Product:      | Clamping unit PGS 25/15/10 for the powRgrip® clamping system                                 |
| Machine type: | PGS 25/15/10 (E/A/J)   |
| Trade name:   | powRgrip® PGS 25/15/10   |
| Position:     | Hydraulic assembly press for clamping and loosening cutting tools using powRgrip® technology |

complies with the essential health and safety requirements of the **Machinery Directive (2006/42/EC)**.

Furthermore, the basic health and safety requirements in accordance with the following guidelines are met:

▲ **Electromagnetic Compatibility Directive (2014/30/EU)**

Assessment of conformity according to 2006/42/EC with internal production control.  
Carrying out risk assessment and risk mitigation in accordance with DIN EN 12100.

This declaration refers to the condition of the machine at the time it was placed on the market.  
Subsequent adaptations, modifications or other interventions in the machine are expressly excluded and require a new declaration of conformity.

Authorised representative for compiling the technical documentation:

Mr Roman Ackeret  
REGO-FIX AG  
Obermattweg 60  
CH-4456 Tenniken



Richard Weber  
CEO



Stefan Weber  
Vice President

Tenniken, 15.07.2024

# 10. Technical data sheet hydraulic oil



LAEMMLE Chemicals AG  
 Öl und Chemie mit Verantwortung  
 Bläsimühle 2 – 6  
 CH-8322 Madetswil  
 +41 44 956 65 65  
 www.laemmlerchemicals.ch



## ROXOR SAMURAI HLP ISO 32

Hydraulik-/Industrieöl auf Mineralölbasis, zinkfrei

### Eigenschaften und Vorteile

- Zink- und aschefreier Hydraulik-/Industrieschmierstoff auf Mineralölbasis mit Additiven gegen Alterung, Korrosion und Verschleiss
- Reduziert wirkungsvoll Verschleiss im Mischreibungsbereich von Hydraulikaggregaten dank ausgezeichneter Anti-Wear-Additive
- Verfügt über ein gutes Wasser- und Luftabscheidevermögen
- Verhält sich neutral gegenüber herkömmlichen Dichtungsmaterialien

### Einsatz (Herstelleranweisungen beachten)

- Für Hydrauliksysteme der Maschinenindustrie
- Für Hydrauliksysteme der Bau- und Forstwirtschaft
- Kompressoren
- Leicht belastete Getriebe
- Werkzeug- und Spritzgussmaschinen
- Pressen
- Hebebühnen
- Steuer- und Regelsysteme

### Spezifikationen

DIN 51 524-2/HLP  
 FZG A/8.3/90: 12  
 ISO 6743-4/LHM

© by LAEMMLE Chemicals AG / NMBF – Änderungen vorbehalten

### Technische Daten (Mittelwerte; es gelten die üblichen Toleranzen)

| ROXOR SAMURAI HLP | Prod. Nr. | Dichte g/cm <sup>3</sup><br>15°C | Viskosität in mm <sup>2</sup> /s |       | Flammpunkt<br>i.o.T. in °C | Pourpoint<br>in °C | Viskositätsindex |
|-------------------|-----------|----------------------------------|----------------------------------|-------|----------------------------|--------------------|------------------|
| ISO 32            | 31764     | 0.875                            | 40°C                             | 100°C |                            |                    |                  |
|                   |           |                                  | 32.0                             | 5.3   | 216                        | -30                | 101              |

### Hinweise

Bitte beachten Sie die Gebindeetikette oder für detaillierte Informationen das Sicherheitsdatenblatt – erhältlich bei LAEMMLE Chemicals AG

31764 TDS de 07.12.2023 ROXOR SAMURAI HLP ISO 32



