



EWS . Varia VX

powRgrip® とEWS Varia VXクイックチェンジシステムによる 段取り時間の短縮

Reduction of set-up time through powRgrip® and the EWS Varia VX quick change system

powRgrip®用Varia VXアダプタ Varia VX-Adapter for powRgrip®

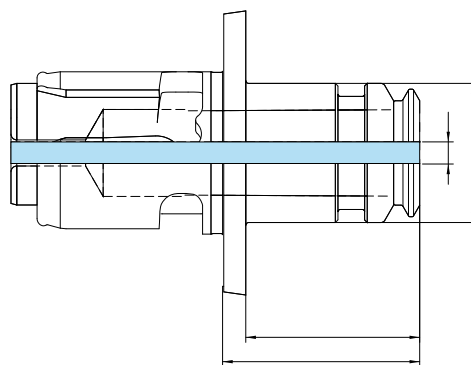

寸法/Dimensions [mm]

製品名/ Type	型番/Part no.	D1	d min.	d max.	L	L1
powRgrip® Varia VX-Adapter						
EWS VX3/PG 15	8350.03150 19.VX3PG15L29.5*	24	3	12.7	34	30
EWS VX4/PG 25**	8350.04251 19.VX4PG25L39*	40	3	20	45	41

*EWS での型番/Part no.

**本製品はPGU専用です/Only to be used with PGU

powRgrip® コレットタイプ powRgrip® collet types



	Std.	CF	CB	L	S	SG	TAP
	標準 Standard	クーラント フラッシュ CoolFlush	クールボア CoolBore	ロング Long	ショート Short	secuRgrip®	タッピング コレット Tapping
主な用途 Application	一般的な マシニング General	軽～中程度 の切削 Easy – Medium	中～重切削 Medium – Heavy	DIN 6535 より長い Length > DIN 6535	DIN 6535 より短い Length < DIN 6535	重切削 Heavy	タッピング Tapping
対応PGサイズ/ PG-Size	15–25	15–25	15–25	15–25	15–25	15–25	15–25
Ø	3–20	3–20	6–20	4–20	4–20	10–20	3.5–16
対応工具径公差 Shank Tolerance	h6	h6	h6	h6	h6	h6	h9
その他の特徴 Features	VEWで工具 長のプリセッ トが可能 Length presetting	VEWで工具 長のプリセッ トが可能 Length presetting	VEWで工具 長のプリセッ トが可能 Length presetting	止めネジ なし No length presetting	VEWで工具 長のプリセッ トが可能 Length presetting	ウェルドン形 状の全ての ツール(DIN 535-HB準 拠)に対応 For Weldon shanks	VEWで工具 長のプリセッ トが可能 Length presetting
クーラント供給 Coolant (peripheral or internal)							

REGO-FIX powRgrip®

簡単 / SIMPLE

ボタンを押すだけ、8秒でクランプ完了

Tool is clamped in 8 seconds by pushing one single button.

安全 / SAFE

加熱なしで強力な把握力を実現

No heat – high clamping force.

powRgrip®

現代的なツールクランプシステム

The tool clamping system of today and tomorrow.



切削工具
Cutting tool



REGO-FIX powRgrip® コレット
REGO-FIX powRgrip® collet



powRgrip® 専用Varia VXアダプタ
Varia VX-adapter for powRgrip®

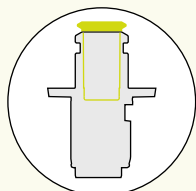

最高の同心度と繰り返し精度
Excellent concentricity with high repeatability.

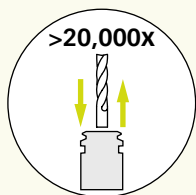

2万回の工具交換後も変わらない把握力と振れ精度
Maximum clamping force and low runout, even after 20,000 tool changes.

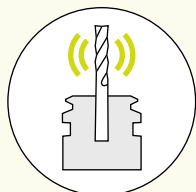

卓越した振動緩衝性
Excellent vibration dampening.

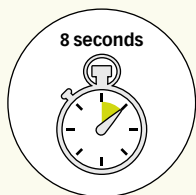

たった8秒で組付け完了
Tool ready for use in 8 seconds.



